



INVERTER

Plug-in option

**FR-A8APD**

INSTRUCTION MANUAL

*Encoder pulse divider*

PRE-OPERATION INSTRUCTIONS	1
INSTALLATION AND WIRING	2
ENCODER PULSE DIVIDER	3
PROTECTIVE FUNCTIONS	4

Thank you for choosing this Mitsubishi Electric inverter plug-in option.

This Instruction Manual provides handling information and precautions for use of this product. Incorrect handling might cause an unexpected fault. Before using this product, read all relevant instruction manuals carefully to ensure proper use.

Please forward this Instruction Manual to the end user.

### Safety instructions

Do not attempt to install, operate, maintain or inspect this product until you have read this Instruction Manual and appended documents carefully. Do not use this product until you have a full knowledge of this product mechanism, safety information and instructions. In this Instruction Manual, the safety instruction levels are classified into "WARNING" and "CAUTION".



#### WARNING

Incorrect handling may cause hazardous conditions, resulting in death or severe injury.



#### CAUTION

Incorrect handling may cause hazardous conditions, resulting in medium or slight injury, or may cause only material damage.

Note that even the  **CAUTION** level may lead to a serious consequence depending on conditions. Be sure to follow the instructions of both levels as they are critical to personnel safety.

#### ◆ Electric shock prevention



#### WARNING

- Do not remove the front cover or the wiring cover of the inverter while the inverter power is ON. Do not operate the inverter with any cover or wiring cover removed, as accidental contact with exposed high-voltage terminals and internal components may occur, resulting in an electrical shock.
- Even if power is OFF, do not remove the front cover of the inverter except for wiring or periodic inspection as you may accidentally touch the charged circuits and get an electric shock.
- Before wiring or inspection, check that the display of the inverter operation panel is OFF. Any person who is involved in wiring or inspection shall wait for 10 minutes or longer after power OFF and check that there are no residual voltage using a tester or the like. The capacitor is charged with high voltage for some time after power OFF, and it is dangerous.
- Any person who is involved in wiring or inspection of this product shall be fully competent to do the work.
- This product must be installed before wiring. Otherwise you may get an electric shock or be injured.
- Do not subject the cables to scratches, excessive stress, heavy loads or pinching. Doing so may cause an electric shock.
- Do not touch this product or handle the cables with wet hands. Doing so may cause an electric shock.

#### ◆ Injury prevention



#### CAUTION

- The voltage applied to each terminal must be as specified in the Instruction Manual. Otherwise a burst, damage, etc. may occur.
- The cables must be connected to the correct terminals. Otherwise a burst, damage, etc. may occur.
- The polarity (+ and -) must be correct. Otherwise a burst, damage, etc. may occur.
- While power is ON or for some time after power OFF, do not touch the inverter as it will be extremely hot. Doing so may cause a burn.

◆ **Additional instructions**

The following instructions must be also followed. If this product is handled incorrectly, it may cause unexpected fault, an injury, or an electric shock.

 **CAUTION**

**Transportation and installation**

- Do not stand or place heavy objects on this product.
- The installing orientation of this product must be correct.
- Do not install or operate this product if it is damaged or has parts missing.
- Foreign conductive objects must be prevented from entering the inverter. That includes screws and metal fragments or other flammable substance such as oil.
- If halogen-based materials (fluorine, chlorine, bromine, iodine, etc.), included in fumigants to sterilize or disinfect wooden packages, infiltrate into this product, the product may be damaged. Prevent residual fumigant components from being infiltrated into the product when packaging, or use an alternative sterilization or disinfection method (heat disinfection, etc.). Note that sterilization or disinfection of wooden package should also be performed before packing the product.

**Test operation**

- Before starting operation, confirm or adjust the parameter settings. Failure to do so may cause some machines to make unexpected motions.

 **WARNING**

**Usage**

- Do not modify this product.
- Do not remove any part which is not instructed to be removed in the Instruction Manuals. Doing so may lead to a failure or damage of this product.

 **CAUTION**

**Usage**

- As all parameters return to their initial values after Parameter clear or All parameter clear is performed, the needed parameters for operation of the inverter and this product must be set again before the operation is started.
- To avoid damage to this product due to static electricity, static electricity in your body must be discharged before you touch this product.

**Maintenance, inspection and parts replacement**

- Do not carry out a megger (insulation resistance) test.

**Disposal**

- This product must be treated as industrial waste.

**General instruction**

- For clarity purpose, illustrations in this Instruction Manual may be drawn with covers or safety guards removed. Ensure all covers and safety guards are properly installed prior to starting operation.

— CONTENTS —

<b>1</b>	<b>PRE-OPERATION INSTRUCTIONS</b>	<b>5</b>
1.1	Unpacking and product confirmation.....	5
1.1.1	Product confirmation.....	5
1.1.2	SERIAL number check .....	6
1.2	Component names .....	7
<b>2</b>	<b>INSTALLATION AND WIRING</b>	<b>8</b>
2.1	Pre-installation instructions .....	8
2.2	Installation procedure .....	8
2.3	Wiring .....	12
2.4	Terminals.....	14
<b>3</b>	<b>ENCODER PULSE DIVIDER</b>	<b>16</b>
3.1	Connection diagram .....	16
3.2	Parameter related to encoder pulse divider.....	18
<b>4</b>	<b>PROTECTIVE FUNCTIONS</b>	<b>19</b>
	<b>APPENDIX</b>	<b>20</b>





# 1 PRE-OPERATION INSTRUCTIONS

## 1.1 Unpacking and product confirmation

Take the product out of the package, check the product name, and confirm that the product is as you ordered and intact. This product is a plug-in option made for the FR-A800 series inverters.

### 1.1.1 Product confirmation

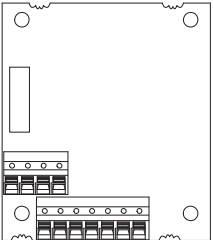
Check the enclosed items.

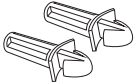
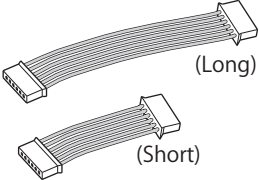
<p>Plug-in option: 1</p> 	<p>Mounting screw (M3 × 8 mm): 2 (Refer to <a href="#">page 8</a>.)</p> 	<p>Spacer: 2 (Refer to <a href="#">page 8</a>.)</p> 	<p>Encoder interface option connection cable: 2*1 (Refer to <a href="#">page 10</a>.)</p> 
--	---	---	---

\*1 Use either one.

#### NOTE

- Connection diagrams in this Instruction Manual appear with the control logic of the input terminals as sink logic, unless otherwise specified. (For the control logic, refer to the Instruction Manual of the inverter.)
- This product does not function on a standalone basis. Always use this product in combination with either of the following encoder interface options. Use the enclosed connection cable to connect this product and the encoder interface option.

**Compatible encoder interface options**

FR-A8AP and FR-A8APA

## 1.1.2 SERIAL number check

The FR-A8APD can be used with the models of inverters listed below which have the following SERIAL number. Check the SERIAL number indicated on the inverter rating plate or package. For the location of the rating plate, refer to the Instruction Manual (Detailed) of the inverter.

Rating plate example

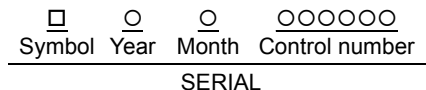
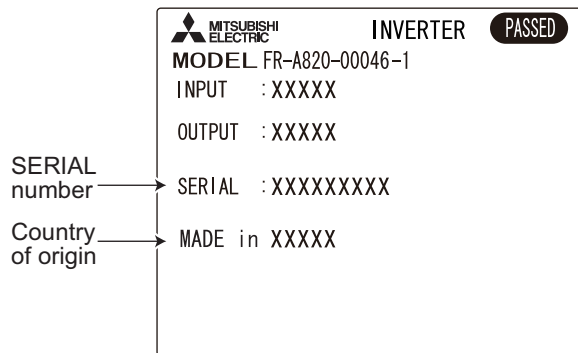

The SERIAL consists of one symbol, two characters indicating the production year and month, and six characters indicating the control number.

The last digit of the production year is indicated as the Year, and the Month is indicated by 1 to 9, X (October), Y (November), or Z (December).

FR-A800 series

Model	Country of origin indication	SERIAL number
FR-A820-00046(0.4K) to 04750(90K) FR-A840-00023(0.4K) to 06830(280K) FR-A842-07700(315K) to 12120(500K) FR-A846-00023(0.4K) to 03610(132K)	MADE in Japan	□83○○○○○○ or later
	MADE in China	□84○○○○○○ or later

## 1.2 Component names

Terminal layout

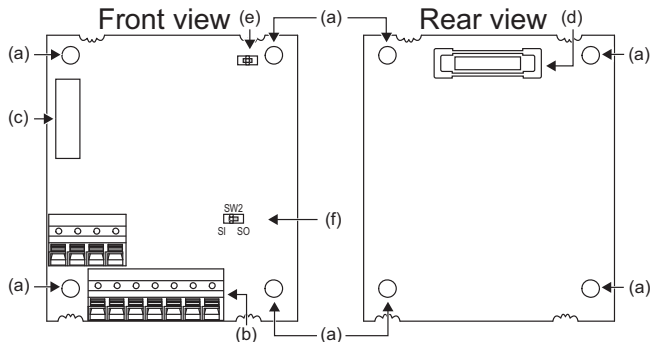
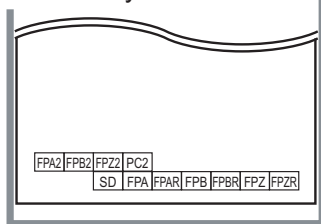

Symbol	Name	Description	Refer to page
a	Mounting hole	Used to fix this product to the inverter by inserting a mounting screw or a spacer.	8
b	Terminal block	Used to connect the terminals of this product and a device which receives the signals from the inverter.	12
c	CON2 connector	Used to connect two options.	—
d	Board mounted option connector	Used to connect this product to the option connector on the inverter.	8
e	Switch for manufacturer setting (SW1)	Do not change the switch setting from the initial setting (  ).	—
f	Sink/source switch (SW2)*1	Used to choose the control logic between sink and source.	—

\*1 This switch allows selection of the control logic between sink and source.

The switch is initially set to the "SI" position.

SI: Sink (initial position)

SO: Source

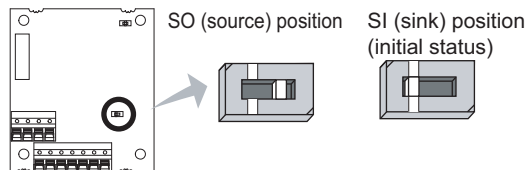

## 2 INSTALLATION AND WIRING

### 2.1 Pre-installation instructions

Check that the inverter's input power and the control circuit power are both OFF.

#### CAUTION

- Do not install or remove this product while the inverter power is ON. Doing so may damage the inverter or this product.
- To avoid damage due to static electricity, static electricity in your body must be discharged before you touch this product.

### 2.2 Installation procedure

- (1) Remove the inverter front cover. (Refer to Chapter 2 of the Instruction Manual (Detailed) of the inverter for instructions for removing the front cover.)
- (2) Insert two spacers into the mounting holes that will not be filled with mounting screws (see the diagrams on the next page to identify the holes ).
- (3) Fit the board mounted option connector on this product to the guide of the option connector on the inverter, and insert the option as far as it goes.
- (4) Fasten this product to the inverter using the two mounting screws through the holes on either side (tightening torque: 0.33 to 0.40 N·m). If the screw holes do not line up, the connector may not be inserted deep enough. Check the connector.

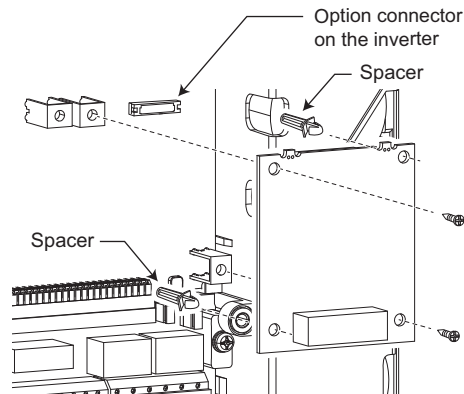

**Example: Attachment of this product to connector 1 on the FR-A800**



- Insertion positions for screws and spacers  
FR-A800

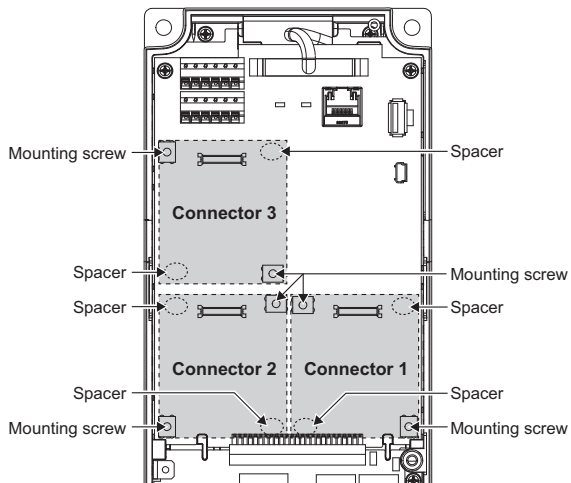

FR-A800-E

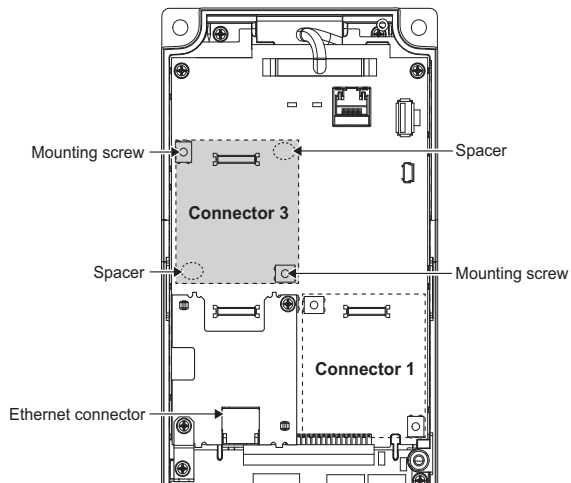

Attach this product to connector 3.  
(Do not attach it to connector 1.)

## ◆ Installation of an encoder interface option

Available combinations of the installation location of two options vary by inverter model. Refer to the following to install two options on the inverter.

Installation example of the FR-A8APD with the FR-A8APA

- (1) Attach the FR-A8APA to connector 1 on the inverter (connector 2 can also be used for the FR-A800).
- (2) Attach the FR-A8APD to connector 2 on the FR-A800 (another empty connector can also be used for the FR-A800), or connector 3 on the FR-A800-E.
- (3) Connect one of the enclosed option connection cables (refer to [page 5](#)) to the CON2 connectors on the FR-A8APD and on the FR-A8APA.

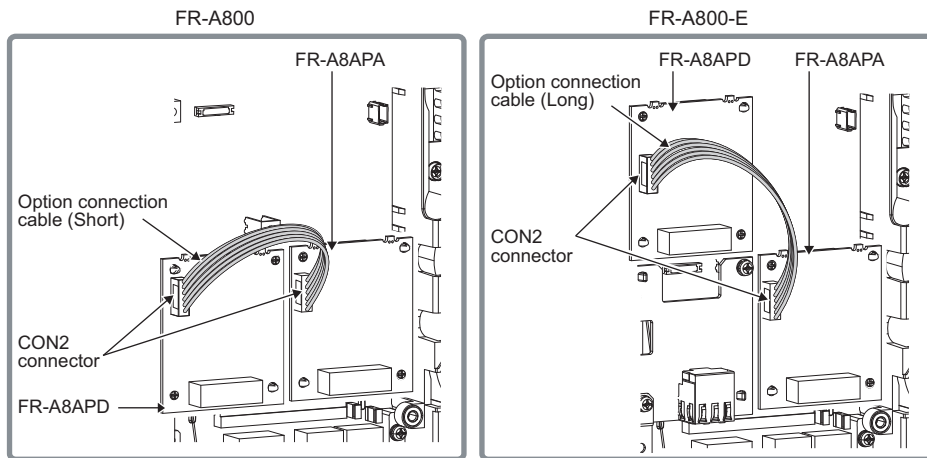

 **NOTE**

- When installing/removing the plug-in option, hold the sides of the option. Do not press on the parts on the option circuit board. Stress applied to the parts by pressing, etc. may cause a failure.
- Be careful not to drop mounting screws during the installation or removal of the plug-in option.
- Only one option attached to the option connector with high priority can function at once if more than one option of the same name are installed together on an inverter. Priority is given to option connectors in descending order (1 to 3), and options having a lower priority do not function.
- When the inverter cannot recognize the option due to improper installation or any other reason, the protective function (E.1 to E.3) is activated and the inverter cannot be operated. The indication shown (when a fault occurs) depends on the connector used (option connector 1 to 3).

Mounted position	Fault indication
Option connector 1	E. 1
Option connector 2	E. 2
Option connector 3	E. 3

- When removing the plug-in option, remove the two screws on either side, and then pull it straight out. Pressure applied to the option connectors and to the option board may break the option.

## 2.3 Wiring

- (1) Strip the signal wires as shown below. If too much of the wire is stripped, a short circuit may occur with neighboring wires. If not enough of the wire is stripped, wires may become loose and fall out. Twist the stripped end of wires to prevent them from fraying. Do not solder it.

Wire strip length



Use appropriate crimp terminals (ferrules, blade terminals, etc.) for these terminal blocks as necessary. When using the crimp terminal, make sure that the stranded wire do not come out of the terminal.

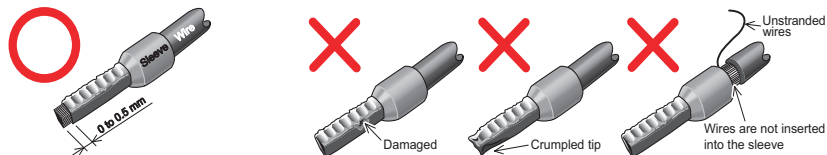

**NOTE**

- Crimp terminals commercially available (as of January 2017. The product may be changed without notice.) Phoenix Contact Co., Ltd.

Terminal screw size	Wire gauge (mm <sup>2</sup> )	Ferrule part No.		Crimping tool model No.
		With insulation sleeve	Without insulation sleeve	
M2	0.3	Al 0,34-6TQ	A 0,34-7	CRIMPFOX 6
	0.5	Al 0,5-6WH	A 0,5-6	

Terminal screw size	Wire gauge (mm <sup>2</sup> )	Blade terminal part No.	Insulation cap part No.	Crimping tool model No.
M2	0.3 to 0.5	BT 0.75-7	VC 0.75	NH 69

When crimping the blade terminal shown above (non-insulated one), make sure that the twisted stripped end do not come out of the terminal.

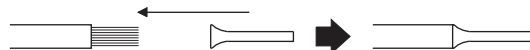

(2) Loosen the terminal screws, and insert each wire into the terminal.

Screw size	Tightening torque (N·m)	Wire gauge (mm <sup>2</sup> )	Driver
M2	0.22 to 0.25	0.3 to 0.75	Small ⊖ flat-blade screwdriver (Tip thickness: 0.4 mm, tip width: 2.5 mm)

#### NOTE

- Under-tightening may cause cable disconnection or malfunction. Over-tightening may cause a short circuit or malfunction due to damage to the screw or option unit.
- When wiring the RS-485 terminals on the inverter with the plug-in options installed, be careful not to let RS-485 cables touch the option circuit boards and the inverter circuit board. This is to prevent a malfunction due to electromagnetic noises.

#### CAUTION

- Do not use empty terminals as junction terminals because they are internally used by the option. Doing so may damage the plug-in option.
- After wiring, do not leave wire offcuts in the inverter. Doing so may cause a fault, failure, or malfunction.

## 2.4 Terminals

Function		Terminal symbol	Terminal (signal) name	Specification	Description
Encoder pulse divider	Open collector	FPA2	Encoder A channel signal output	Open collector output. Permissible load: 24 VDC at 50 mA max.	Outputs the encoder A channel, B channel, or Z channel (home position or mark pulse) signals. The A and B channel output signals can be divided by a dividing factor "N" (N: an integer between 1 to 32767). Use <b>Pr.413 Encoder pulse division ratio</b> to specify the factor N. Common terminal is terminal PC2.
		FPB2	Encoder B channel signal output		
		FPZ2	Encoder Z channel signal output		
		PC2	Open collector output common	—	

Function		Terminal symbol	Terminal (signal) name	Specification	Description
Encoder pulse divider	Differential line driver	FPA	Encoder A channel differential signal output	Differential line driver output. Permissible load: 40 mA.	Outputs the encoder A channel, B channel, or Z channel (home position or mark pulse) signals. The A and B channel output signals can be divided by a dividing factor "N" (N: an integer from 1 to 32767). Use <b>Pr.413 Encoder pulse division ratio</b> to specify the factor N. Common terminal is terminal SD.
		FPAR	Encoder A channel complementary (inverted) differential signal output		
		FPB	Encoder B channel differential signal output		
		FPBR	Encoder B channel complementary (inverted) differential signal output		
		FPZ	Encoder Z channel differential signal output		
		FPZR	Encoder Z channel complementary (inverted) differential signal output		
	SD	Differential line driver output common	—	Common terminal for the differential line driver output terminals, or common terminal for the open collector output terminals when sink logic is selected.	

# 3 ENCODER PULSE DIVIDER

The FR-A8APD divides the encoder signals input to the encoder interface option, and outputs them from its terminals.

## 3.1 Connection diagram

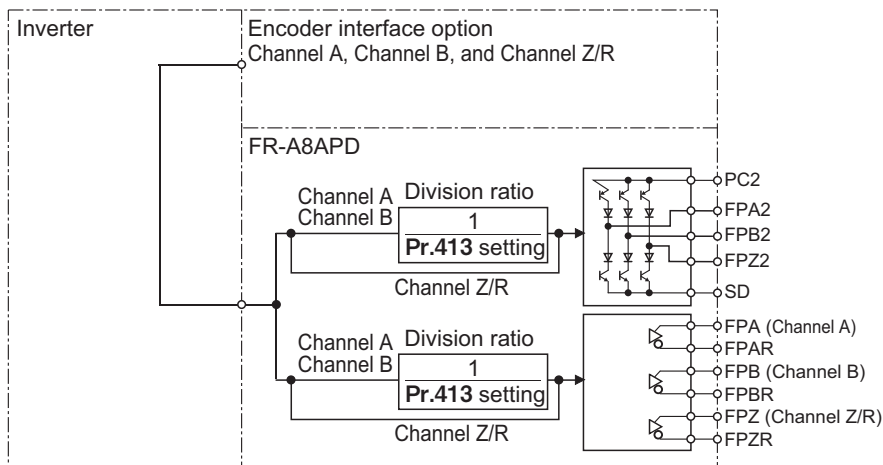



## NOTE

- For the open collector output, the signal may become unstable if the input resistance of the connected device is large and the device may detect the signal incorrectly. In this case, adding a pull-up resistor, as shown below, will improve the phenomenon.
- Select an appropriate pull-up resistor in consideration of the input current of the connected device so that the open collector output current will not exceed the output permissible load current.

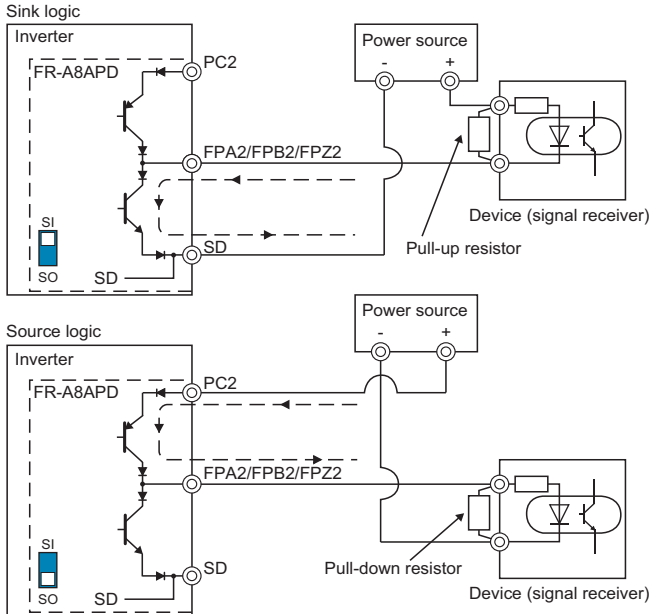

## 3.2 Parameter related to encoder pulse divider

Pr.	Pr. group	Name	Initial value	Setting range	Description
413	M601	Encoder pulse division ratio	1	1 to 32767	The encoder pulse divider option divides pulse signals input from a motor encoder by the number set in <b>Pr.413</b> , and outputs them. This parameter is useful for the purpose, for example, of decreasing the speed of response of a device which receives the signals from the option.

- Division waveform by division ratio  
Every cycle (a range of ON to OFF) of the waveform (50% duty cycle) is divided by the dividing factor.
  - Output pulse waveform example at 1000 pulses input when **Pr.413** = "2"

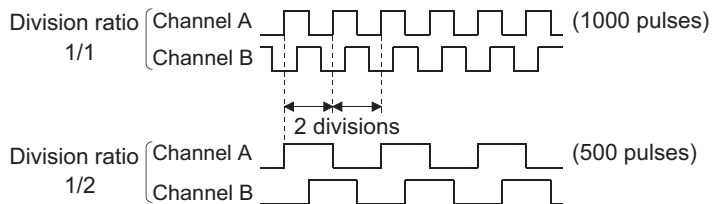

### NOTE

- Encoder rotation direction (forward/reverse) determined by the phase difference between channel A and channel B  
When A channel signal leads B channel signal by 90 degrees: Forward rotation  
When B channel signal leads A channel signal by 90 degrees: Reverse rotation

## 4 PROTECTIVE FUNCTIONS

The causes and corrective actions of faults are as follows.

### ◆ Fault

When a protective function is activated, the inverter output is shut off and a fault signal is output.

To resume the inverter operation after any protective function has been activated, refer to the Instruction Manual (Detailed) of the inverter to take an appropriate corrective action and reset the inverter.

Operation panel indication	E.OPT		FR-LU08 indication	Option Fault
<b>Name</b>	Option fault			
<b>Description</b>	Appears when the FR-A8APD and an encoder interface option are installed on an inverter but they are not connected correctly with the option connection cable for the inverter operation.			
<b>Point to be checked</b>	Check that the FR-A8APD and the encoder interface option are connected correctly with the option connection cable.			
<b>Corrective action</b>	Connect the FR-A8APD and the encoder interface option correctly and securely with the option connection cable (refer to <a href="#">page 10</a> ).			

# APPENDIX

## Restricted Use of Hazardous Substances in Electronic and Electrical Products

The mark of restricted use of hazardous substances in electronic and electrical products is applied to the product as follows based on the “Management Methods for the Restriction of the Use of Hazardous Substances in Electrical and Electronic Products” of the People’s Republic of China.

电器电子产品有害物质限制使用标识要求



本产品中所含有的有害物质的名称、含量、含有部件如下表所示。

- 产品中所含有害物质的名称及含量

部件名称*2	有害物质*1					
	铅 (Pb)	汞 (Hg)	镉 (Cd)	六价铬 (Cr (VI))	多溴联苯 (PBB)	多溴二苯醚 (PBDE)
电路板组件 (包括印刷电路板及其构成的零部件, 如电阻、电容、集成电路、连接器等)、电子部件	×	○	×	○	○	○
金属壳体、金属部件	×	○	○	○	○	○
树脂壳体、树脂部件	○	○	○	○	○	○
螺丝、电线	○	○	○	○	○	○

上表依据SJ/T11364的规定编制。

○：表示该有害物质在该部件所有均质材料中的含量均在GB/T26572规定的限量要求以下。

×：表示该有害物质在该部件的至少一种均质材料中的含量超出GB/T26572规定的限量要求。

\*1 即使表中记载为 ×，根据产品型号，也可能会有有害物质的含量为限制值以下的情况。

\*2 根据产品型号，一部分部件可能不包含在产品中。

# MEMO

# MEMO

## REVISIONS

\*The manual number is given on the bottom left of the back cover.

Print date	*Manual number	Revision
Feb. 2018	IB(NA)-0600795ENG-A	First edition

INVERTER

**mitsubishi** **Electric Corporation**

HEAD OFFICE: TOKYO BUILDING 2-7-3, MARUNOUCHI, CHIYODA-KU, TOKYO 100-8310, JAPAN