



INVERTER

Plug-in option

FR-A8AL

INSTRUCTION MANUAL

Orientation control

Encoder feedback control

Vector control

Position control

Encoder pulse dividing output

PRE-OPERATION INSTRUCTIONS	1
INSTALLATION	2
ENCODER SPECIFICATIONS AND PARAMETER SETTINGS	3
ORIENTATION CONTROL	4
ENCODER FEEDBACK CONTROL	5
VECTOR CONTROL	6
POSITION CONTROL FUNCTION	7
ENCODER PULSE DIVIDING OUTPUT	8

Thank you for choosing this Mitsubishi Electric inverter plug-in option.

This Instruction Manual provides handling information and precautions for use of this product. Incorrect handling might cause an unexpected fault. Before using this product, read all relevant instruction manuals carefully to ensure proper use.

Please forward this Instruction Manual to the end user.

Safety instructions

Do not attempt to install, operate, maintain or inspect this product until you have read this Instruction Manual and appended documents carefully. Do not use this product until you have a full knowledge of this product mechanism, safety information and instructions. In this Instruction Manual, the safety instruction levels are classified into "WARNING" and "CAUTION".



WARNING

Incorrect handling may cause hazardous conditions, resulting in death or severe injury.



CAUTION

Incorrect handling may cause hazardous conditions, resulting in medium or slight injury, or may cause only material damage.

Note that even the  **CAUTION** level may lead to a serious consequence depending on conditions. Be sure to follow the instructions of both levels as they are critical to personnel safety.

◆ Electric shock prevention



WARNING

- Do not remove the front cover or the wiring cover of the inverter while the inverter power is ON. Do not operate the inverter with any cover or wiring cover removed, as accidental contact with exposed high-voltage terminals and internal components may occur, resulting in an electrical shock.
- Even if power is OFF, do not remove the front cover of the inverter except for wiring or periodic inspection as you may accidentally touch the charged circuits and get an electric shock.
- Before wiring or inspection, check that the display of the inverter operation panel is OFF. Any person who is involved in wiring or inspection shall wait for 10 minutes or longer after power OFF and check that there are no residual voltage using a tester or the like. The capacitor is charged with high voltage for some time after power OFF, and it is dangerous.
- Any person who is involved in wiring or inspection of this product shall be fully competent to do the work.
- This product must be installed before wiring. Otherwise you may get an electric shock or be injured.
- Do not subject the cables to scratches, excessive stress, heavy loads or pinching. Doing so may cause an electric shock.
- Do not touch this product or handle the cables with wet hands. Doing so may cause an electric shock.

◆ Injury prevention



CAUTION

- The voltage applied to each terminal must be as specified in the Instruction Manual. Otherwise a burst, damage, etc. may occur.
- The cables must be connected to the correct terminals. Otherwise a burst, damage, etc. may occur.
- The polarity (+ and -) must be correct. Otherwise a burst, damage, etc. may occur.
- While power is ON or for some time after power OFF, do not touch the inverter as it will be extremely hot. Doing so may cause a burn.

◆ Additional instructions

The following instructions must be also followed. If this product is handled incorrectly, it may cause unexpected fault, an injury, or an electric shock.

CAUTION

Transportation and installation

- Do not stand or place heavy objects on this product.
- The installing orientation of this product must be correct.
- Do not install or operate this product if it is damaged or has parts missing.
- Foreign conductive objects must be prevented from entering the inverter. That includes screws and metal fragments or other flammable substance such as oil.
- If halogen-based materials (fluorine, chlorine, bromine, iodine, etc.), included in fumigants to sterilize or disinfect wooden packages, infiltrate into this product, the product may be damaged. Prevent residual fumigant components from being infiltrated into the product when packaging, or use an alternative sterilization or disinfection method (heat disinfection, etc.). Note that sterilization or disinfection of wooden package should also be performed before packing the product.

Test operation

- Before starting operation, confirm or adjust the parameter settings. Failure to do so may cause some machines to make unexpected motions.

WARNING

Usage

- Do not modify this product.
- Do not remove any part which is not instructed to be removed in the Instruction Manuals. Doing so may lead to a failure or damage of this product.

CAUTION

Usage

- As all parameters return to their initial values after Parameter clear or All parameter clear is performed, the needed parameters for operation of the inverter and this product must be set again before the operation is started.
- To avoid damage to this product due to static electricity, static electricity in your body must be discharged before you touch this product.

Maintenance, inspection and parts replacement

- Do not carry out a megger (insulation resistance) test.

Disposal

- This product must be treated as industrial waste.

General instruction

- For clarity purpose, illustrations in this Instruction Manual may be drawn with covers or safety guards removed. Ensure all covers and safety guards are properly installed prior to starting operation.

— CONTENTS —

1	PRE-OPERATION INSTRUCTIONS	6
1.1	Unpacking and product confirmation	6
1.1.1	Product confirmation	6
1.1.2	SERIAL number check	7
1.2	Component names	8
2	INSTALLATION	9
2.1	Pre-installation instructions	9
2.2	Installation procedure	10
2.3	Encoder specification / terminating resistor switch setting	13
2.4	Wiring	15
2.5	Encoder cables dedicated to Mitsubishi Electric motors	19
2.6	Terminals	21
3	ENCODER SPECIFICATIONS AND PARAMETER SETTINGS	26
3.1	Encoder	26
3.2	Parameter setting	28
3.2.1	Parameter for encoder	28
3.2.2	Parameter settings for the motor under vector control	30
4	ORIENTATION CONTROL	31
4.1	Wiring example	31
4.2	Terminals	33

4.3	Machine end simple orientation control	34
4.4	Specifications.....	35
5	ENCODER FEEDBACK CONTROL	36
5.1	Wiring examples	36
5.2	Specifications.....	37
6	VECTOR CONTROL	38
6.1	Wiring examples	38
6.2	Pulse train torque command	41
6.2.1	Parameter list	41
6.2.2	Pulse train torque command.....	42
6.3	Specifications.....	43
7	POSITION CONTROL FUNCTION	44
7.1	Position control.....	44
7.2	Wiring example	47
7.3	Operation	48
7.4	Interface of the positioning module and inverter	51
7.5	Parameter setting and details.....	52
7.5.1	Block diagram.....	52
7.5.2	Selection of control method (Pr.800).....	52
7.5.3	Position control	53
7.5.4	Troubleshooting.....	55
7.6	Specifications.....	56



8 ENCODER PULSE DIVIDING OUTPUT	57
8.1 Wiring example	57
8.2 Parameter related to encoder pulse dividing output.....	59
APPENDIX	60

1 PRE-OPERATION INSTRUCTIONS

1.1 Unpacking and product confirmation

Take the plug-in option out of the package, check the product name, and confirm that the product is as you ordered and intact. This product is a plug-in option made for the FR-A800 series.

1.1.1 Product confirmation

◆ Product confirmation

Check the enclosed items.

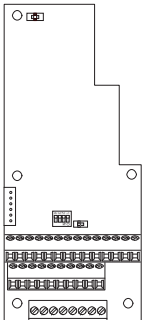
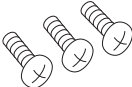
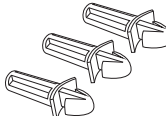
Plug-in option.....1 	Mounting screw (M3 × 8 mm)....3 (Refer to page 10.) 	Spacer.....3 (Refer to page 10.) 
---	--	---

NOTE

- Connection diagrams in this Instruction Manual appear with the control logic of the input terminals as sink logic, unless otherwise specified. (For the control logic, refer to the Instruction Manual (Detailed) of the inverter.)

1.1.2 SERIAL number check

The FR-A8AL can be used for the inverter models listed below with the following SERIAL number. Check the SERIAL number indicated on the inverter rating plate or package. For the location of the rating plate, refer to the Instruction Manual (Detailed) of the inverter.

Rating plate example

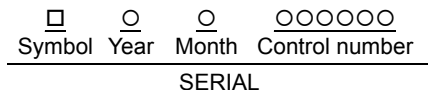
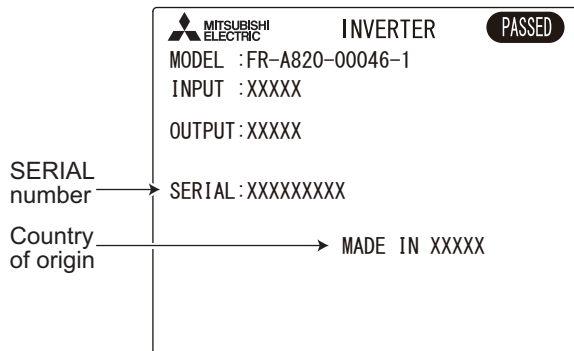



The SERIAL consists of one symbol, two characters indicating the production year and month, and six characters indicating the control number. The last digit of the production year is indicated as the Year, and the Month is indicated by 1 to 9, X (October), Y (November), or Z (December).

- FR-A800 series

Model	Country of origin indication	SERIAL number
FR-A820-00046(0.4K) to 04750(90K) FR-A840-00023(0.4K) to 06830(280K) FR-A842-07700(315K) to 12120(500K) FR-A846-00023(0.4K) to 00470(18.5K)	MADE in Japan	□58○○○○○○ or later
	MADE in China	□59○○○○○○ or later

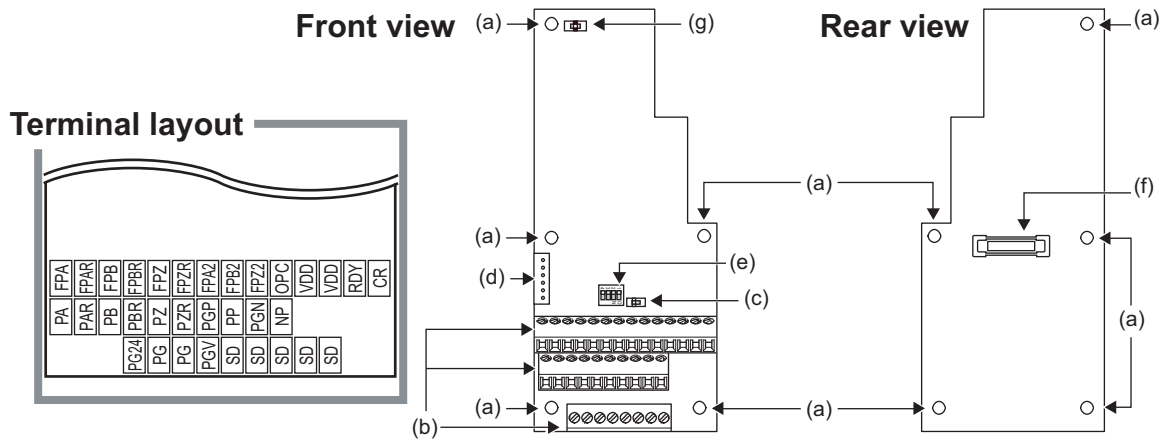
1.2 Component names



Symbol	Name	Description	Refer to page
a	Mounting hole	Used to fix this product to the inverter by inserting a mounting screw or a spacer.	10
b	Terminal block	Connected with the encoder.	15
c	Encoder type selection switch (SW3)	Used to switch the encoder type (differential line driver/ complementary).	13
d	CON2 connector	Connector for the FR-A8NS (SSCNET III) connection	—
e	Terminating resistor selection switches (SW2-1 to SW2-3)	Used to switch ON or OFF the internal terminating resistor.	13
	Encoder power supply selection switch (SW2-4)	Used to switch the voltage supplied to the encoder from terminal PGV.	
f	Board mounted option connector	Used to connect this product to the option connector on the inverter.	10
g	Switch for manufacturer setting (SW1)	Do not change the switch setting from the initial setting ().	—

2 INSTALLATION

2.1 Pre-installation instructions

Check that the inverter's input power and the control circuit power are both OFF.



CAUTION

- Do not install or remove this product while the inverter power is ON. Doing so may damage the inverter or this product.
- To avoid damage due to static electricity, static electricity in your body must be discharged before you touch this product.

2.2 Installation procedure

- (1) Remove the inverter front cover. (Refer to Chapter 2 of the Instruction Manual (Detailed) of the inverter for instructions for removing the front cover.)
- (2) As shown in the next page, when the plug-in option is installed to the connector 1, insert spacers in the three mounting holes that will not be tightened with mounting screws. (When the plug-in option is installed to the connector 2, insert spacers in the two mounting holes.)
- (3) Fit the board mounted option connector on this product to the guide of the option connector on the inverter and insert the plug-in option as far as it goes.
- (4) When the plug-in option is installed to the connector 1, fit the two locations, the left and right, of the product securely to the inverter unit by screwing in the supplied mounting screws. (When the plug-in option is installed to the connector 2, fit the three locations.) (tightening torque 0.33 N·m to 0.40 N·m). If the screw holes do not line up, the connector may not be inserted deep enough. Check the connector.

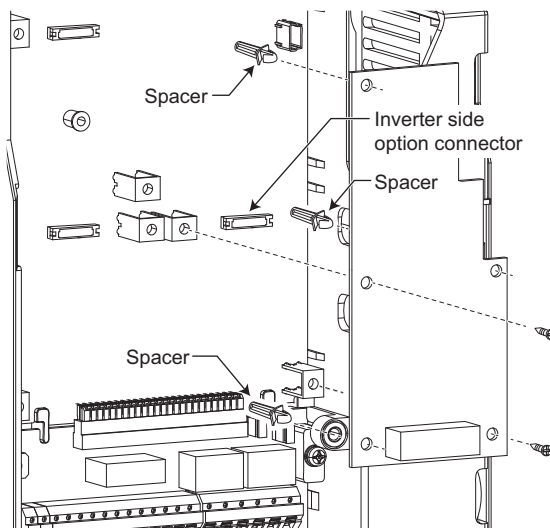

Example of installation to connector 1

NOTE

- When a communication option is installed to the FR-A800-E/FR-F800-E series inverter, use the earthing (grounding) cable supplied with the inverter instead of the earth plate supplied with the communication option. (For details of the installation method, refer to the Instruction Manual of the inverter.)

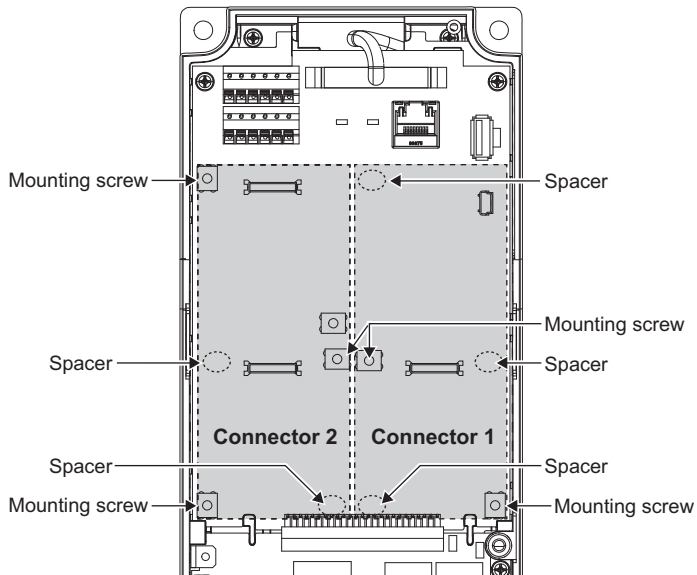

Insertion positions for screws and spacers

NOTE

- When installing/removing the plug-in option, hold the sides of the option. Do not press on the parts on the option circuit board. Stress applied to the parts by pressing, etc. may cause a failure.
- Be careful not to drop mounting screws during the installation or removal of the plug-in option.
- The priorities of vector control compatible plug-in options are defined as follows: FR-A8AL > FR-A8APS > FR-A8APA > FR-A8APR > FR-A8AP. The vector control compatible plug-in options with lower priority do not function.
- Only one option can be used. When multiple options are mounted, priority is given to option connectors 1, 2 and 3 on the inverter in this order, and options having a lower priority do not function.
- When the inverter cannot recognize the option due to improper installation or any reason, the protective function (E.1 to E.3) is activated and the inverter cannot be operated. The indication shown (when a fault occurs) depends on the connector used (option connector 1 to 3).

Mounted position	Fault indication
Option connector 1	E. 1
Option connector 2	E. 2
Option connector 3	E. 3

- When removing the plug-in option, remove the two screws on either side, and then pull it straight out. Pressure applied to the option connector and to the option board may break the option.

2.3 Encoder specification / terminating resistor switch setting

◆ Encoder specification selection switch (SW3)

Select either differential line driver or complementary.

It is initially set to the complementary. Switch its position according to output circuit.

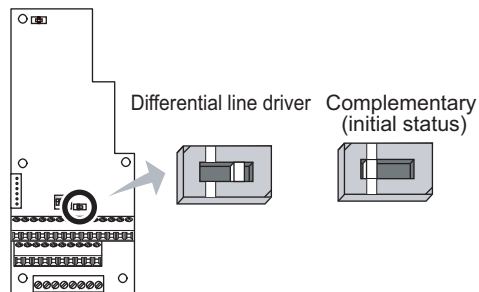

◆ Terminating resistor selection switches (SW2-1 to SW2-3)

Select "ON"/"OFF" of the internal terminating resistor. Set the SW2-1 to SW2-3 switches to "ON" when an encoder output type is differential line driver and set to "OFF" when complementary (initial status).

ON : with internal terminating resistor

OFF : without internal terminating resistor (initial status)

◆ Encoder power supply selection switch (SW2-4)

Select 5 V or 12 V power to be supplied to the encoder from terminal PGV.

Set SW2-4 to the ON position for the 12 V power supply, or set SW2-4 to the OFF position (initial status) for the 5 V power supply.

When power is supplied to the encoder from terminal PGV, connect terminal PGV and terminal PG.

Internal terminating resistor-ON

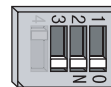

Internal terminating resistor-OFF (initial status)



5 V power supply for the encoder (initial status)

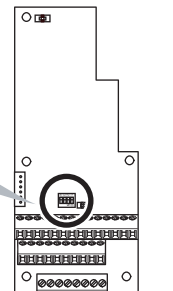

12 V power supply for the encoder

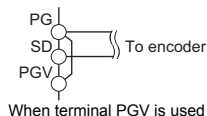

NOTE

- If the encoder output type is differential line driver, set the terminating resistor switch to the "OFF" position when sharing the same encoder with other unit (CNC (computerized numerical controller), etc.) or a terminating resistor is connected to other unit.
- Terminals PGV and PG24 cannot be used simultaneously.
- When using terminal PGV to supply power to the encoder, check that the voltage setting meets the encoder specification. Applying a voltage exceeding the encoder specification may damage the encoder.

◆ Motor used and switch setting

Motor		Encoder specification selection switch (SW3)	Terminating resistor selection switches (SW2 -1 to SW2-3)	Power specifications*2
Mitsubishi Electric standard motor with encoder Mitsubishi Electric high-efficiency motor with encoder	SF-JR	Differential	ON	5 V
	SF-HR	Differential	ON	5 V
	Others	*1	*1	*1*3
Mitsubishi Electric constant-torque motor with encoder	SF-JRCA	Differential	ON	5 V
	SF-HRCA	Differential	ON	5 V
	Others	*1	*1	*1*3
Vector control dedicated motor	SF-V5RU	Complementary	OFF	12 V / 24 V
Other manufacturer's motor with encoder		*1	*1	*1*3

*1 Set according to the motor encoder used.

*2 Depending on the encoder to be used, prepare an external power supply (15 V) for the encoder. When the 24 V power supply of the FR-A8AL is used, the power is supplied to the encoder through terminal PG24. When the 5 V/12 V power supply of the FR-A8AL is used, the power is supplied to the encoder through terminal PGV.

*3 When the encoder output is the differential line driver type, only 5 V can be input.

NOTE

- Switch "SW1" is for manufacturer setting. Do not change the setting.
- When an external power supply is used for the encoder, turn OFF the encoder's power supply while power is not supplied to the control circuit of the inverter. Otherwise, the plug-in option may be damaged.

2.4 Wiring

(1) Use twisted pair shield cables (0.2 mm² or larger) to connect the FR-A8AL and position detector.

For the wiring to the terminals PG and SD, use several cables in parallel or use a thick cable, according to the wiring length. To protect the cables from noise, run them away from any source of noise (e.g. the main circuit and power voltage).

Wiring length	Parallel connection (Cable gauge 0.2 mm ²)	Larger-size cable
Within 10 m	At least two cables in parallel	0.4 mm ² or larger
Within 20 m	At least four cables in parallel	0.75 mm ² or larger
Within 100 m *1	At least six cables in parallel	1.25 mm ² or larger

*1 When differential driver is set and a wiring length is 30 m or more
The wiring length can be extended to 100 m by slightly increasing the 5 V power supply (approx. 5.5 V) and using six or more cables with gauge size of 0.2 mm² in parallel or a cable with gauge size of 1.25 mm² or more. Note that the voltage applied should be within power supply specifications of encoder.

To reduce noise of the encoder cable, earth (ground) the encoder shielded cable to the enclosure (as close as the inverter) with a P clip or U clip made of metal.

NOTE

- For details of the optional encoder dedicated cable (FR-JCBL/FR-V7CBL), refer to [page 19](#).
- FR-V7CBL is provided with a P clip for earthing (grounding) shielded cable.

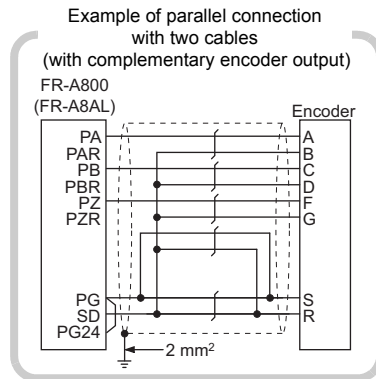

Earthing (grounding) example using a P clip

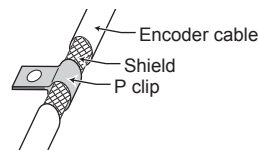

(2) Wire the shielded twisted pair cable after stripping its sheath to make its cables loose. Also, protect the shielded cable of the shielded twisted pair cable to ensure that it will not make contact with the conductive area.

Strip the signal wires as shown below. If too much of the wire is stripped, a short circuit may occur with neighboring wires.

If not enough of the wire is stripped, wires may become loose and fall out.

Twist the stripped end of wires to prevent them from fraying. Do not solder it.

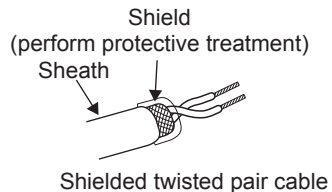

Wire strip length

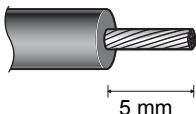

Use appropriate crimp terminals (ferrules, blade terminals, etc.) for these terminal blocks as necessary. When using the crimp terminal, make sure that the stranded wire do not come out of the terminal.

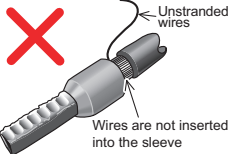
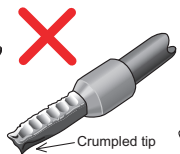
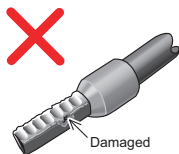
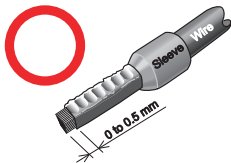

NOTE

Crimp terminals commercially available (as of January 2017. The product may be changed without notice.)

- Phoenix Contact Co., Ltd.

Terminal screw size	Wire gauge (mm ²)	Ferrule part No.		Crimping tool model No.
		With insulation sleeve	Without insulation sleeve	
M2	0.3	AI 0,34-6TQ	A 0,34-7	CRIMPFOX 6
	0.5	AI 0,5-6WH	A 0,5-6	

- NICHIFU Co., Ltd.

Terminal screw size	Wire gauge (mm ²)	Blade terminal part No.	Insulation cap part No.	Crimping tool model No.
M2	0.3 to 0.75	BT 0.75-7	VC 0.75	NH 69

- When using a blade terminal (without insulation sleeve), take caution that the twisted wires do not come out.

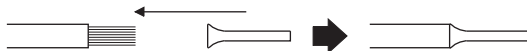

(3) Loosen the terminal screw and insert the cable into the terminal.

Screw size	Tightening torque	Wire gauge	Screwdriver
M2	0.22 N·m to 0.25 N·m	0.3 mm ² to 0.75 mm ²	Small ⊖ flat-blade screwdriver (Tip thickness: 0.4 mm/tip width: 2.5 mm)

NOTE

- Under-tightening may cause cable disconnection or malfunction. Over-tightening may cause a short circuit or malfunction due to damage to the screw or option unit.
- When wiring the RS-485 terminals on the inverter with the plug-in options installed, be careful not to let RS-485 cables touch the option circuit boards and the inverter circuit board. This is to prevent a malfunction due to electromagnetic noises.
- When one position detector is shared between FR-A8AL and CNC (computerized numerical controller), its output signal should be connected as shown below. In this case, the wiring length between FR-A8AL and CNC should be as short as possible, within 5 m.

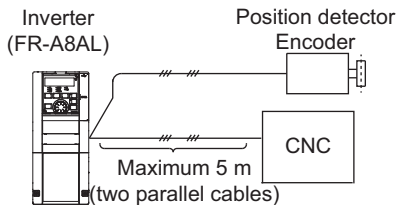

CAUTION

- Do not use empty terminals as junction terminals because they are internally used by the option. Doing so may damage the plug-in option.
- After wiring, do not leave wire offcuts in the inverter. Doing so may cause a fault, failure, or malfunction.

2.5 Encoder cables dedicated to Mitsubishi Electric motors

Use dedicated encoder cables to connect with Mitsubishi Electric encoder-equipped motors.

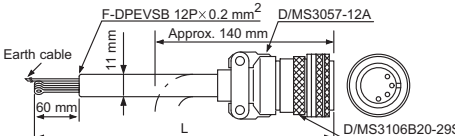
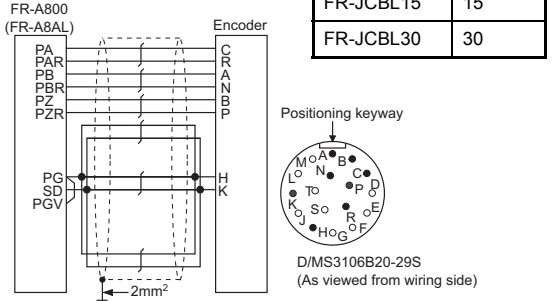
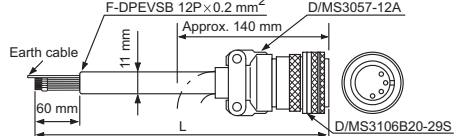
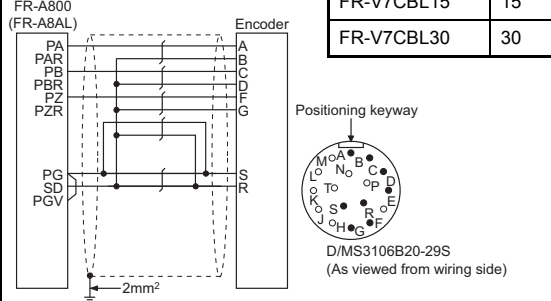
FR-JCBL	FR-V7CBL																
<p>For SF-JR/HR/JRCA/HRCA (with encoder)</p>  <p>• 1</p> <table border="1" style="margin-left: auto; margin-right: auto;"> <thead> <tr style="background-color: #00FFFF;"> <th>Type</th> <th>Length L (m)</th> </tr> </thead> <tbody> <tr> <td>FR-JCBL5</td> <td>5</td> </tr> <tr> <td>FR-JCBL15</td> <td>15</td> </tr> <tr> <td>FR-JCBL30</td> <td>30</td> </tr> </tbody> </table> 	Type	Length L (m)	FR-JCBL5	5	FR-JCBL15	15	FR-JCBL30	30	<p>For SF-V5RU and SF-THY</p>  <p>• A P clip for earthing (grounding) a shielded cable is provided.</p> <table border="1" style="margin-left: auto; margin-right: auto;"> <thead> <tr style="background-color: #00FFFF;"> <th>Type</th> <th>Length L (m)</th> </tr> </thead> <tbody> <tr> <td>FR-V7CBL5</td> <td>5</td> </tr> <tr> <td>FR-V7CBL15</td> <td>15</td> </tr> <tr> <td>FR-V7CBL30</td> <td>30</td> </tr> </tbody> </table> 	Type	Length L (m)	FR-V7CBL5	5	FR-V7CBL15	15	FR-V7CBL30	30
Type	Length L (m)																
FR-JCBL5	5																
FR-JCBL15	15																
FR-JCBL30	30																
Type	Length L (m)																
FR-V7CBL5	5																
FR-V7CBL15	15																
FR-V7CBL30	30																

• 1 As the terminal block of the FR-A8AL is an insertion type, earth (ground) cables need to be modified. (Refer to [page 16](#).)

2

◆ **Connection terminal compatibility table**

Motor		SF-JR/HR/JRCA/HRCA (with encoder)	SF-V5RU, SF-THY
Encoder cable		FR-JCBL	FR-V7CBL
FR-A8AL terminal	PA	PA	PA
	PAR	PAR	Keep this open.
	PB	PB	PB
	PBR	PBR	Keep this open.
	PZ	PZ	PZ
	PZR	PZR	Keep this open.
	PG	5E	PG
	SD	AG2	SD

2.6 Terminals

Function	Terminal symbol	Terminal (signal) name	Specification	Description	
Position control function	PGP PP	Forward rotation pulse train	Open collector/ differential line driver	Forward rotation pulse train input terminal. Input pulse train from the pulse generating unit.	For open collector, connect terminal VDD and OPC, then input pulses across terminal PP-SD and NP-SD. For differential line driver, open terminal OPC, then input pulse across terminal PP-PGP and NP-PGN.
	PGN NP	Reverse rotation pulse train		Reverse rotation pulse train input terminal. Input pulse train from the pulse generating unit.	
	CR	Clear	—	Short across terminals CR and SD to clear the values of the position pulse-1 at the trailing edge of the signal.	
	OPC	Open collector power input	24 VDC	When inputting pulse by open collector method, connect this terminal to terminal VDD (24 V power supply)	
	SD	Contact input common	—	Contact input common terminal. Do not earth (ground).	
	VDD	Driver power supply	24 VDC	Driver power supply terminal for interface.	
	RDY	Preparation ready signal	—	When servo ON and ready to drive, the signal is output.	
	FPZ2	Encoder Z-phase output	Open collector output permissible load 24 VDC, max. 50 mA	Outputs one pulse per motor revolution.	

*1 For details of the position pulse, refer to the Instruction Manual (Detailed) of the inverter.

Function	Terminal symbol	Terminal (signal) name	Specification	Description	
Encoder pulse input	PA	Encoder A-phase signal input	Differential line driver/ complementary	A-, B- and Z-phase signals are input from the encoder.	
	PAR	Encoder A-phase inverse signal input			
	PB	Encoder B-phase signal input			
	PBR	Encoder B-phase inverse signal input			
	PZ	Encoder Z-phase signal input			
	PZR	Encoder Z-phase inverse signal input			
	PG	Power supply (positive side) input	—	Input power for the encoder power supply. Connect the external power supply (15 V) and the encoder power cable. When the encoder output is the differential line driver type, only 5 V can be input. Make sure the voltage of the external power supply the same as the encoder output voltage. (Check the encoder specification.) If using the 24 V power supply of the FR-A8AL, 24 V power can be supplied from terminal PG24.	
	SD	Encoder pulse dividing output common		—	Common terminal for the encoder pulse dividing output terminal.
		24 V encoder power supply common			Common terminal for the 24 V encoder power supply terminal (terminal PG24).
		12 V encoder power supply common			Common terminal for the 12 V encoder power supply terminal (terminal PGV).
5 V encoder power supply common		Common terminal for the 5 V encoder power supply terminal (terminal PGV).			



- When the input power supply voltage to the encoder and its output voltage differ, the signal loss detection (E.ECT) may occur.

Function	Terminal symbol	Terminal (signal) name	Specification	Description	
Encoder pulse division output	Open collector	FPA2	Encoder A-phase signal output	Open collector output Permissible load 24 VDC max. 50 mA	Outputs the A-phase, B-phase and Z-phase (origin and mark pulse) signals from the encoder. The A-phase and B-phase signals can be divided by the ratio (1/n) and output. n=1 to 32767 (integer). Set using Pr.413 Encoder pulse division ratio . Common terminal is terminal SD.
		FPB2	Encoder B-phase signal output		
		FPZ2	Encoder Z-phase signal output		
	Differential line driver	FPA	Encoder differential A-phase signal output	Differential line driver output Permissible load 40 mA	Outputs the A-phase, B-phase and Z-phase (origin and mark pulse) signals from the encoder. The A-phase and B-phase signals can be divided by the ratio (1/n) and output. n=1 to 32767 (integer). Set using Pr.413 Encoder pulse division ratio .
		FPAR	Encoder differential A-phase inverse signal output		
		FPB	Encoder differential B-phase signal output		
		FPBR	Encoder differential B-phase inverse signal output		
		FPZ	Encoder differential Z-phase signal output		
		FPZR	Encoder differential Z-phase inverse signal output		

Function	Terminal symbol	Terminal (signal) name	Specification	Description	
Power supply output for encoder	PG24	Encoder power supply terminal (positive side)	24 to 26.4 VDC 80 mA	Used for the 24 VDC power supply for an encoder. If used, connect this terminal to terminal PG, and this will supply power from the terminal PG to the encoder.	
	PGV	Encoder power supply terminal (positive side)	10.8 to 13.2 VDC 120 mA	Used for the power supply for an encoder. When the encoder power supply selection switch (SW2-4) is set to the ON position, the terminal can be used as the 12 V power supply for the encoder. If used, connect this terminal to terminal PG, and this will supply power through terminal PG to the encoder.	
			4.5 to 5.5 VDC 300 mA	Used for the power supply for an encoder. When the encoder power supply selection switch (SW2-4) is set to the OFF position (initial status), the terminal can be used as the 5 V power supply for the encoder. If used, connect this terminal to terminal PG, and this will supply power through terminal PG to the encoder.	
	PG	Power supply (positive side) output	—	Connected to the power terminal (positive side) on the encoder. Connect this terminal to the positive pole of the external power supply or to terminal PG24 or PGV (connected to the positive pole of an internal power supply of this product) to supply power to the positive power terminal on the encoder. When the encoder output is the differential line driver type, be sure to select 5 V output.	
	SD	24 V encoder power supply common	—	Common terminal for the 24 V encoder power supply terminal (terminal PG24).	Connected to the power terminal (negative side) on the encoder.
		12 V encoder power supply common		Common terminal for the 12 V encoder power supply terminal (terminal PGV).	
5 V encoder power supply common		Common terminal for the 5 V encoder power supply terminal (terminal PGV).			

NOTE

- Do not use the encoder power supply output terminals (PG24 and PGV) except for supplying power to the encoder.
- The 5 V or 12 V output voltage can be selected by setting the encoder power supply selection switch (SW2-4). Always use the output voltage setting that meets the encoder voltage specifications. Applying an incorrect voltage may damage the encoder.
- Connect the encoder power supply terminals as follows.

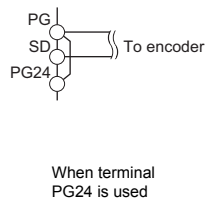
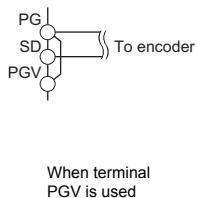
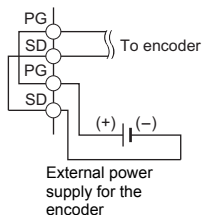

3 ENCODER SPECIFICATIONS AND PARAMETER SETTINGS

3.1 Encoder

◆ Position detection (pulse encoder)

Output pulse specifications

Differential line driver

A/ \bar{A} signal 1000 P/R to 4096 P/R

B/ \bar{B} signal 1000 P/R to 4096 P/R

Z/ \bar{Z} signal 1 P/R

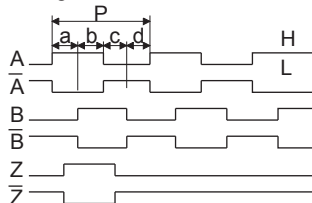

Complementary

A signal 1000 P/R to 4096 P/R

B signal 1000 P/R to 4096 P/R

Z signal 1 P/R

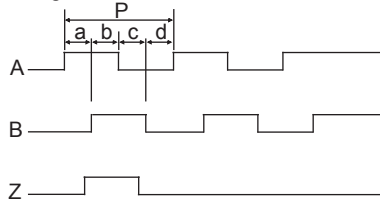

Position detector
Encoder

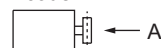

- When rotation is clockwise as viewed from the shaft end (A) of the encoder.
- a, b, c, d should be $(1/4 \pm 1/8)P$

NOTE

- When orientation control, encoder feedback control, vector control are used together, the encoder is shared between these controls.
Use an encoder which has a pulse count of 1000 to 4096 ppr (pulse per revolution).
- The encoder should be coupled with the motor shaft or the spindle oriented with a speed ratio of 1 to 1 without any mechanical looseness.
- To ensure correct operation, the encoder must be set in the proper rotation direction and the A and B phases connected correctly.

◆ Power supply

Choose a power supply for encoder according to the encoder used (15 V etc.). When the encoder output is the differential line driver type, only 5 V can be input. Make sure the voltage of the external power supply the same as the encoder output voltage. (Check the encoder specification.) Use terminal PG24 for the 24 V encoder's power supply. Use terminal PGV for the 5 V/12 V encoder's power supply.

When an encoder is used under orientation control, encoder feedback control, and vector control, the power supply is shared between the inverter and encoder.

- Specifications of the encoders equipped in the motors with encoders and the vector-control dedicated motors



Item	Encoder for SF-JR/HR/JRCA/HRCA	Encoder for SF-V5RU, SF-THY
Resolution	1024 pulses/rev	2048 pulses/rev
Power supply voltage	5 VDC±10%	12 VDC±10%
Output signal form	A, B phases (90° phase shift) Z phase: 1 pulse/rev	
Output circuit	Differential line driver AM26LS31 equivalent	Complementary
Output voltage	H level: 2.4 V or more L level: 0.5 V or less	H level: "Power supply for encoder-3 V" or more L level: 3 V or less

NOTE

- When the input power supply voltage to the encoder and its output voltage differ, the protective function (E.ECT) may be activated.
- When an external power supply is used for the encoder, turn OFF the encoder's power supply while power is not supplied to the control circuit of the inverter. Otherwise, the plug-in option may be damaged.

3.2 Parameter setting

3.2.1 Parameter for encoder

Parameter Number	Pr. group	Name	Initial Value	Setting Range	Description	
359	C141	Encoder rotation direction	1	0	Set when using a motor for which forward rotation (encoder) is clockwise (CW) viewed from the shaft	Set for the operation at 120 Hz or less.
				100		Set for the operation at a frequency higher than 120 Hz.
				1	Set when using a motor for which forward rotation (encoder) is counterclockwise (CCW) viewed from the shaft	Set for the operation at 120 Hz or less.
				101		Set for the operation at a frequency higher than 120 Hz.
369	C140	Number of encoder pulses	1024	0 to 4096	Set the number of encoder pulses output. Set the number of pulses before it is multiplied by 4.	
862	C242	Encoder option selection	0	0	First motor: FR-A8AL, Second motor: FR-A8TP	
				1	First motor: FR-A8TP, Second motor: FR-A8AL	

NOTE

- If operating at a frequency higher than 120 Hz with **Pr.359** = "0 or 1", the motor rotation will be unstable.

- Using the FR-A8TP together with the plug-in option FR-A8AL enables vector control or machine end orientation control by switching between two encoder-equipped motors. Use **Pr.862** to set the combination of the motors (first/second) and the options (FR-A8TP/FR-A8AL).

Pr.862 Encoder option selection	Pr.393 Orientation selection	RT signal-OFF (First motor)	RT signal-ON (Second motor)*1	Machine end orientation control
0 (initial value)	0, 1, 2	FR-A8AL	FR-A8TP	Disabled
	10, 11, 12			
1	0, 1, 2	FR-A8TP	FR-A8AL	
	10, 11, 12	Motor end: FR-A8TP Machine end: FR-A8AL	—	

*1 When **Pr.450 Second applied motor** = "9999", the first motor is selected even if the RT signal turns ON.

- Use the following parameters for the encoder input setting. The encoder input setting can be made regardless of the **Pr.862** setting and first/second motor setting.

Parameter name	Parameter for control terminal option (FR-A8TP)	Parameter for plug-in option (FR-A8AL)
Encoder rotation direction	852	359
Number of encoder pulses	851	369
Encoder signal loss detection enable/disable selection	855	376



- To input the RT signal, set "3" in any of **Pr.178 to Pr.182**, **Pr.185**, or **Pr.189** (input terminal function selection) to assign the function to a terminal.

3.2.2 Parameter settings for the motor under vector control

Motor name		Pr.359 Encoder rotation direction	Pr.369 Number of encoder pulses
Mitsubishi Electric standard motor	SF-JR	1 (Initial value)	1024 (Initial value)
	SF-JR 4P 1.5 kW or less	1 (Initial value)	1024 (Initial value)
	SF-HR	1 (Initial value)	1024 (Initial value)
	Others	*1	*1
Mitsubishi Electric constant-torque motor	SF-JRCA 4P	1 (Initial value)	1024 (Initial value)
	SF-HRCA 4P	1 (Initial value)	1024 (Initial value)
	Others	*1	*1
Vector control dedicated motor	SF-V5RU	1 (Initial value)	2048
	SF-THY	1 (Initial value)	2048
Other manufacturer's standard motor	—	*1	*1
Other manufacturer's constant-torque motor	—	*1	*1

*1 Set this parameter according to the motor (encoder) used.

4 ORIENTATION CONTROL

This function is used with a position detector (encoder) installed to the spindle of a machine tool, etc. to allow a rotary shaft to be stopped at the specified position (oriented).

For the details of the parameters used for orientation control, refer to the Instruction Manual (Detailed) of the inverter.

4.1 Wiring example

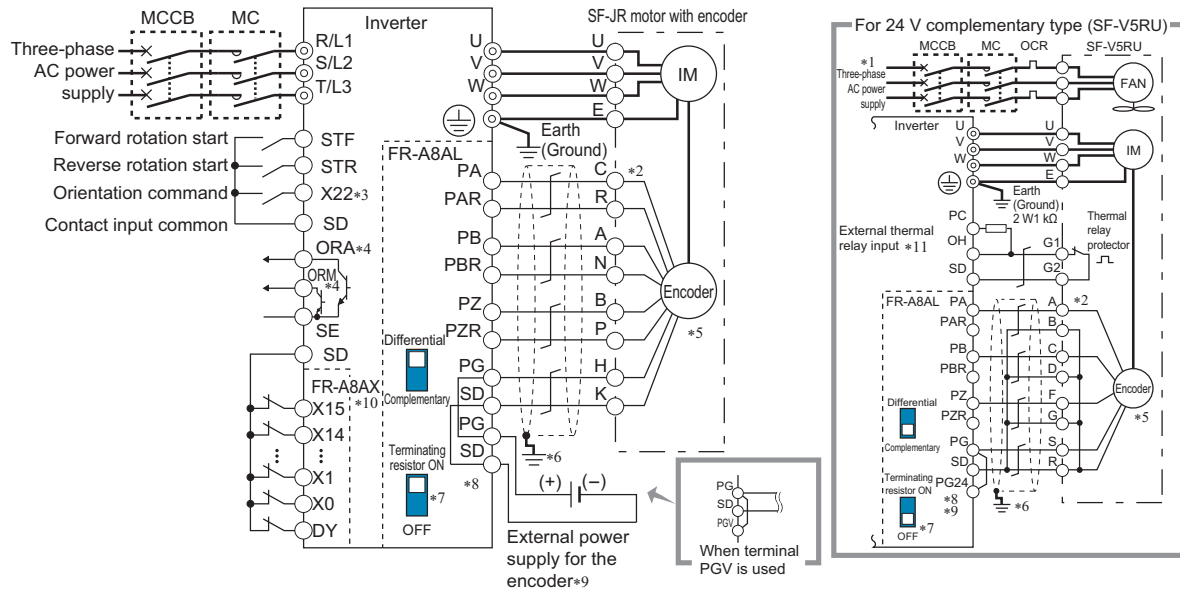

- *1 For the fan of the 7.5 kW or less dedicated motor, the power supply is single phase (200 V/50 Hz, 200 to 230 V/ 60 Hz).
- *2 The pin number differs according to the encoder used.
- *3 Use **Pr.178 to Pr.189 (input terminal function selection)** to assign the function to any of terminal.
Refer to the Instruction Manual (Detailed) for details of **Pr.178 to Pr.189 (input terminal function selection)**.
- *4 Use **Pr.190 to Pr.196 (output terminal function selection)** to assign the function to any of terminal.
Refer to the Instruction Manual (Detailed) for details of **Pr.190 to Pr.196 (output terminal function selection)**.
- *5 Connect the encoder so that there is no looseness between the motor and motor shaft. Speed ratio should be 1:1.
- *6 Earth (Ground) the shielded cable of the encoder cable to the enclosure with a P clip, etc. (Refer to [page 15](#).)
- *7 For the differential line driver, set the terminating resistor selection switch to on position (initial status) to use. (Refer to [page 13](#).)
Note that the terminating resistor switch should be set to off position when sharing the same encoder with other unit (CNC, etc.) and a terminating resistor is connected to other unit. For the complementary, set the switch to off position.
- *8 For terminal compatibility of the FR-JCBL, FR-V7CBL and FR-A8AP, refer to [page 20](#).
- *9 A separate external power supply of 15 V is necessary according to the encoder power specification. When the encoder output is the differential line driver type, only 5 V can be input. If using the 24 V power supply of the FR-A8AL, the power can be supplied from terminal PG24. If using the 5 V/12 V power supply of the FR-A8AL, the power can be supplied from terminal PGV. Do not use the external power supply simultaneously with the 5 V/12 V power supply or the 24 V power supply.
Make the voltage of the external power supply the same as the encoder output voltage, and connect the external power supply between terminals PG and SD.
When performing encoder feedback control and vector control together, an encoder and power can be shared.
- *10 When a stop position command is input from outside, a plug-in option FR-A8AX is necessary. Refer to the Instruction Manual (Detailed) for details of external stop position command.
- *11 To use a terminal as the terminal OH, assign the OH (external thermal O/L relay input) signal to an input terminal. (Set "7" in any of **Pr.178 to Pr.189**. For details, refer to the Instruction Manual (Detailed) of the inverter.)

4.2 Terminals

◆ Option FR-A8AX terminal

Terminal symbol	Terminal name	Description
X0 to X15	Digital signal input terminal	Input the digital signal at the relay contact or open collector terminal. Using Pr.360 , speed or position command is selected as the command signal entered.
DY	Data read timing input signal terminal	Used when a digital signal read timing signal is necessary. Data is read only during the DY signal is on. By switching the DY signal off, the X0 to X15 data before signal-off is retained.

◆ Inverter terminal

Terminal (signal)		Terminal (signal) name	Application explanation
Input	X22	Orientation command	Used to enter an orientation signal for orientation. For the terminal used for X22 signal input, set "22" in any of Pr.178 to Pr.189 to assign the function. *1
Output	ORA	Orientation complete	Switched LOW if the orientation has stopped within the in-position zone while the start and X22 signals are input. For the terminal used for the ORA signal output, assign the function by setting "27 (positive logic) or 127 (negative logic)" in any of Pr.190 to Pr.196 . *1
	ORM	Orientation fault	Switched LOW if the orientation has not completed within the in-position zone while the start and X22 signals are input. For the terminal used for the ORA signal output, assign the function by setting "28 (positive logic) or 128 (negative logic)" in any of Pr.190 to Pr.196 . *1

*1 Refer to the Instruction Manual (Detailed) for details of **Pr.178 to Pr.189 (input terminal function selection)** and **Pr.190 to Pr.196 (output terminal function selection)**.

4.3 Machine end simple orientation control

Pr.	Pr. group	Name	Initial value	Setting range	Description
369	C140	Number of encoder pulses	1024	0 to 4096	Set the number of motor end encoder pulses converted from the number of machine end encoder pulses.
829	A546	Number of machine end encoder pulses	9999	0 to 4096	Set the number of pulses of the encoder connected to the machine end. Set the number of pulses before multiplied by four.
				9999	Machine end orientation cannot be performed.

To enable encoder feedback control / vector control and the machine end orientation control at the same time using the machine end encoder, set the number of machine end encoder pulses in **Pr.829 Number of machine end encoder pulses**.

Pr.829 setting	Pr.862 setting	Description
9999	—	Machine end simple orientation control invalid
Other than 9999 (A number of machine end encoder pulses (before multiplied by four) is set.)	0	The machine end encoder enables encoder feedback control / vector control and the machine end orientation control at the same time.
	1	Machine end simple orientation control invalid

• Setting example

When the number of machine end encoder pulses is 4000 pulses and the gear ratio of the motor end and the machine end is 4:1 (for every four revolutions of the motor, the machine makes one revolution)

$$\text{Number of encoder pulses equivalent to the number of motor end pulses} = 4000 \times 1/4 = 1000$$

Therefore, set **Pr.369** = "1000" and **Pr.829** = "4000" (number of machine end encoder pulses).



NOTE

- Refer to the Instruction Manual of the Inverter for details on the encoder feedback control, vector control and orientation control.

4.4 Specifications

Repeated positioning accuracy	$\pm 1.5^\circ$ Depends on the load torque, moment of inertia of the load or orientation, creep speed, position loop switching position, etc.
Permissible speed	Encoder-mounted shaft speed (6000 r/min with 1024-pulse encoder). The drive shaft and encoder-mounted shaft must be coupled directly or via a belt without any slip. Gear changing shafts cannot be applied.
Functions	Orientation, creep speed setting, stop position command selection, DC injection brake start position setting, creep speed and position loop switch position setting, position shift, orientation in-position, position pulse monitor, etc.
Holding force after positioning	Under V/F control, Advanced magnetic flux vector control...without servo lock function Under vector control...with servo lock function
Input signal (contact input)	Orientation command, forward and reverse rotation commands, stop position command (open collector signal input (complementary) is enabled) Binary signal of maximum 16 bits (when used with the FR-A8AX)
Output signal (open collector output)	Orientation completion signal, orientation fault signal

5 ENCODER FEEDBACK CONTROL

Mount FR-A8AL to an FR-A800 series inverter to perform encoder feedback control under V/F control or Advanced magnetic flux vector control.

This controls the inverter output frequency so that the motor speed is constant to the load variation by detecting the motor speed with the speed detector (encoder) to feed back to the inverter.

For the details of the parameters used for encoder feedback control, refer to the Instruction Manual (Detailed) of the inverter.

5.1 Wiring examples

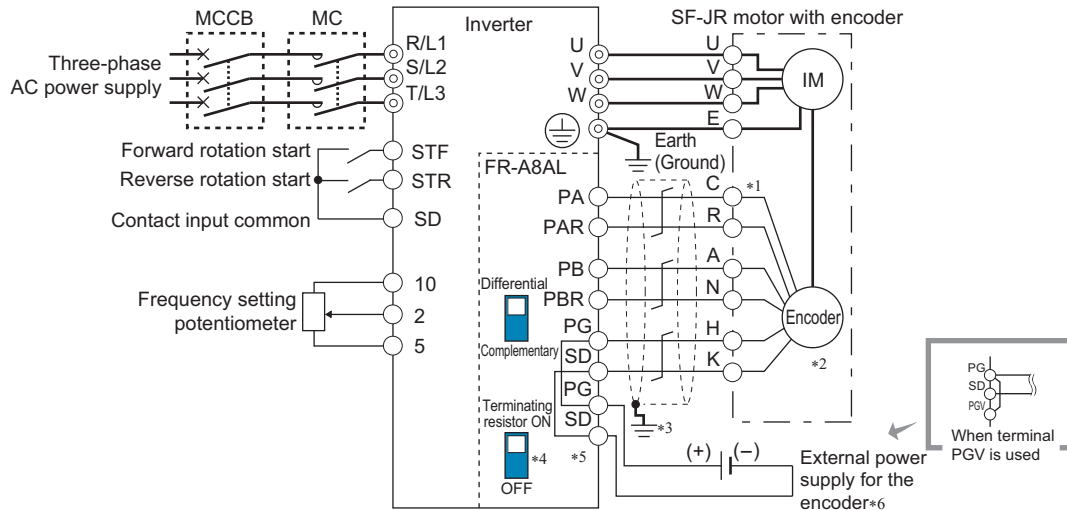

- *1 The pin number differs according to the encoder used.
- *2 Connect the encoder so that there is no looseness between the motor and motor shaft. Speed ratio should be 1:1.
- *3 Earth (Ground) the shielded cable of the encoder cable to the enclosure with a P clip, etc. (Refer to [page 15](#).)
- *4 For the differential line driver, set the terminating resistor selection switch to on position (initial status) to use. (Refer to [page 13](#).) Note that the terminating resistor switch should be set to off position when sharing the same encoder with other unit (CNC, etc) and a terminating resistor is connected to other unit.
For the complementary, set the switch to off position.
- *5 For terminal compatibility of the FR-JCBL, FR-V7CBL and FR-A8AP, refer to [page 20](#).
- *6 A separate external power supply of 15 V is necessary according to the encoder power specification. When the encoder output is the differential line driver type, only 5 V can be input. If using the 24 V power supply of the FR-A8AL, the power can be supplied from terminal PG24. If using the 5 V/12 V power supply of the FR-A8AL, the power can be supplied from terminal PGV. Do not use the external power supply simultaneously with the 5 V/12 V power supply or the 24 V power supply.
Make the voltage of the external power supply the same as the encoder output voltage, and connect the external power supply between terminals PG and SD.
To perform orientation control together, an encoder and power supply can be shared.

5.2 Specifications

Speed variation ratio	±0.1% (100% means 3600 r/min)
Function	<ul style="list-style-type: none"> • Setting of speed feedback range • Setting of feedback gain • Setting of encoder rotation direction
Maximum speed	V/F control: 590 Hz, Advanced magnetic flux vector control: 400 Hz (102400 pulse/s or less encoder pulses)

6 VECTOR CONTROL

When FR-A8AL is mounted on the FR-A800 series, full-scale vector control operation can be performed using a motor with encoder.

Speed control, torque control and position control by vector control can be performed. (Refer to the Instruction Manual (Detailed) for details.)

6.1 Wiring examples

◆ Speed control

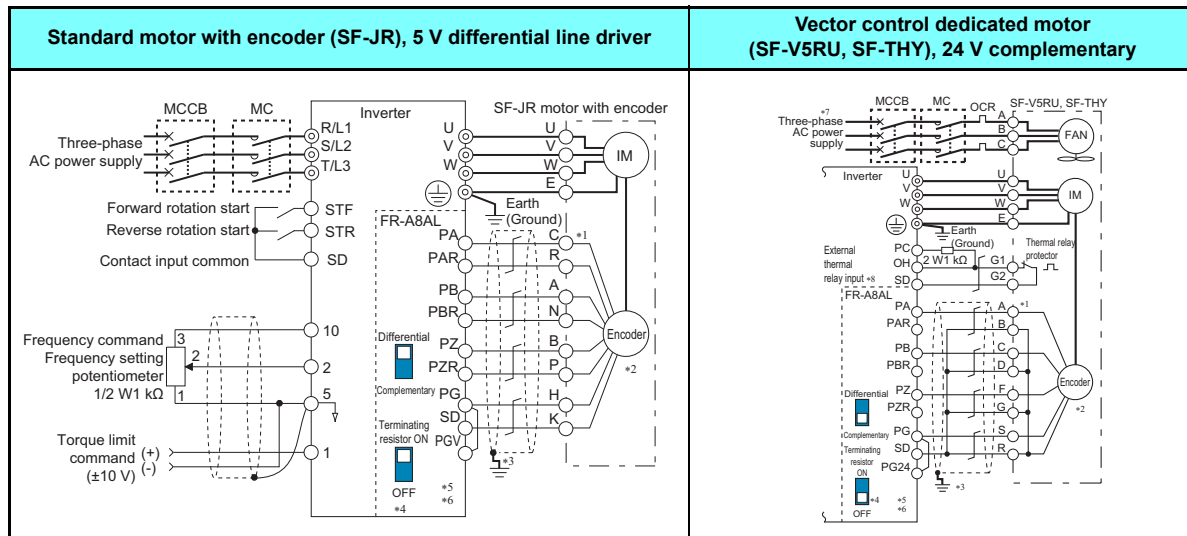

◆ Torque control

Standard motor with encoder (SF-JR), 5 V differential line driver

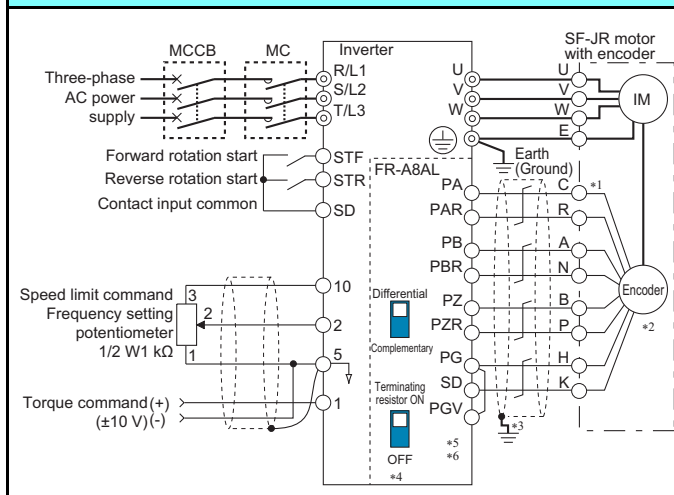

Vector control dedicated motor (SF-V5RU, SF-THY), 24 V complementary

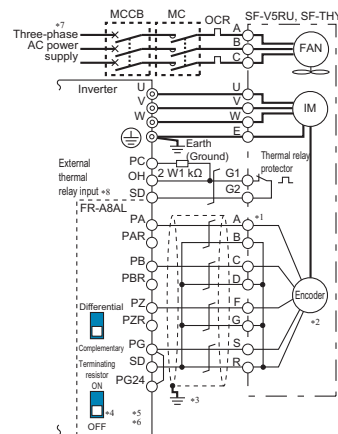

◆ Position control (simple positioning with pulse train input via terminal JOG on the inverter)

Vector control dedicated motor (SF-V5RU, SF-THY), 24 V complementary

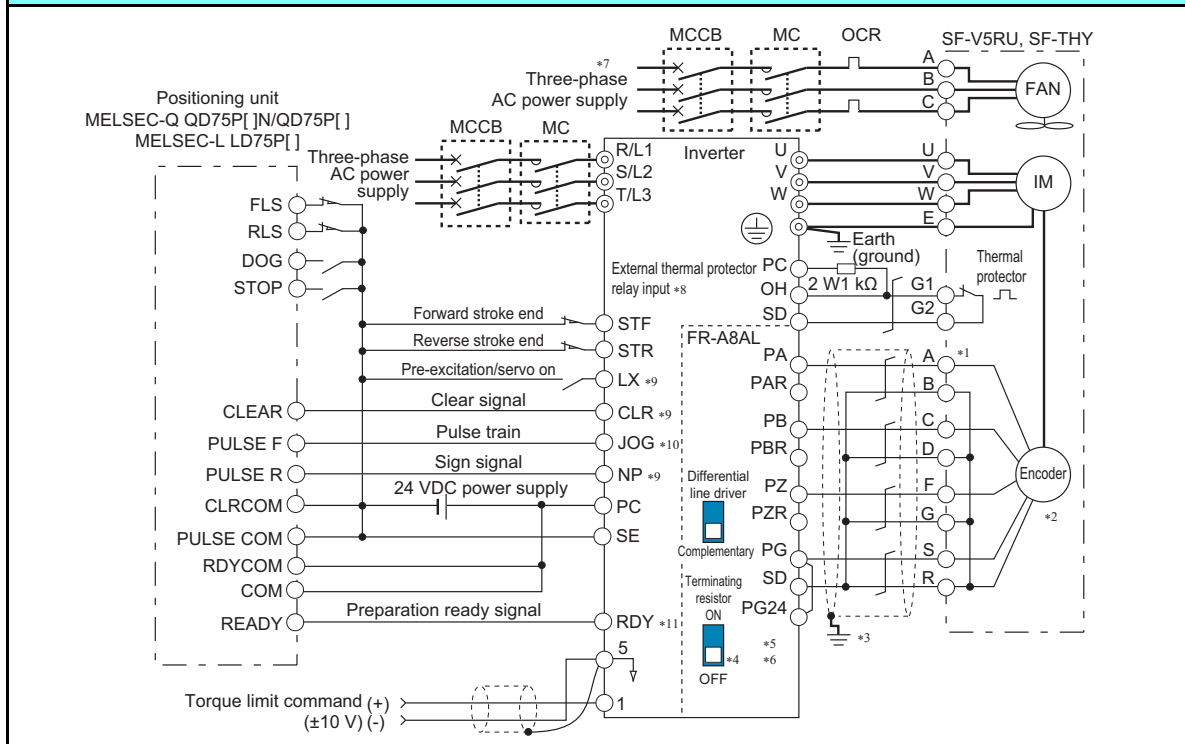

- *1 The pin number differs according to the encoder used.
Speed, control, torque control, and position control by pulse train input are available with or without the Z-phase being connected.
- *2 Connect the encoder so that there is no looseness between the motor and motor shaft. Speed ratio must be 1:1.
- *3 Earth (ground) the shield of the encoder cable to the enclosure using a tool such as a P-clip. (Refer to [page 15](#).)
- *4 For the complementary, set the terminating resistor selection switch to OFF position. (Refer to [page 13](#).)
- *5 A separate external power supply of 15 V is necessary according to the encoder power specification. When the encoder output is the differential line driver type, only 5 V can be input. If using the 24 V power supply of the FR-A8AL, the power can be supplied from terminal PG24. If using the 5 V/12 V power supply of the FR-A8AL, the power can be supplied from terminal PGV. Do not use the external power supply simultaneously with the 5 V/12 V power supply or the 24 V power supply.
Make the voltage of the external power supply the same as the encoder output voltage, and connect the external power supply between terminals PG and SD.
- *6 For terminal compatibility of the FR-JCBL, FR-V7CBL, and FR-A8AP, refer to [page 20](#).
- *7 For the fan of the 7.5 kW or lower dedicated motor, the power supply is single phase. (200 V/50 Hz, 200 to 230 V/60 Hz)
- *8 To use a terminal as the terminal OH, assign the OH (external thermal O/L relay input) signal to an input terminal. (Set "7" in any of **Pr.178 to Pr.189**. For details, refer to the Instruction Manual (Detailed) of the inverter.)
- *9 Assign the function using **Pr.178 to Pr.189 (input terminal function selection)**.
- *10 When position control is selected, terminal JOG function is invalid and simple position pulse train input terminal becomes valid.
- *11 Assign the function using **Pr.190 to Pr.194 (output terminal function selection)**.

6.2 Pulse train torque command

6.2.1 Parameter list

Pr.	Pr. group	Name	Setting range	Initial value
428	B009	Command pulse selection	0 to 5	0
432	D120	Pulse train torque command bias	0 to 400%	0%
433	D121	Pulse train torque command gain	0 to 400%	150%
800	G200	Control method selection	0 to 6, 9 to 14, 20, 100 to 106, 109 to 114	20
804	D400	Torque command source selection	0 to 6	0

6.2.2 Pulse train torque command

◆ Pulse train torque command setting

When torque control is selected, setting "2" in **Pr.804 Command pulse selection** enables torque command by pulse train input. Set the **Pr.800** setting to "1, 2, or 5" to perform torque control. (When setting "2 or 5", torque control need to be selected by MC terminal switchover.) The inverter and torque command pulse train interface should be matched. (Refer to [page 38](#) for wiring.)

◆ Pulse train torque command calibration

Set bias (**Pr.432**) and gain (**Pr.433**) to the torque command. The relationship between input pulse and torque command value is shown on the right.

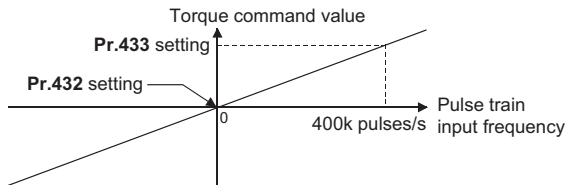

6.3 Specifications

Speed control	Speed control range	1:1500 (both driving/regeneration *1)
	Speed variation ratio	±0.01% (100% means 3000 r/min)
	Speed response	130 Hz
	Maximum speed	400 Hz (102400 pulse/s or less encoder pulses)
Torque control	Torque control range	1:50
	Absolute torque accuracy	±10% *2
	Repeated torque accuracy	±5% *2
Position control	Repeated positioning accuracy	±1.5° (at motor shaft end)
	Maximum input pulse frequency	100k pulses/s (Terminal JOG)
	Positioning feedback pulse	Number of encoder pulses per motor rotation (Pr.369) × 4
	Electronic gear setting	1/50 to 20
	In-position width	0 to 32767 pulses
	Error excess	0 to 400k pulses
Function	<ul style="list-style-type: none"> • Setting of speed feedback range • Setting of feedback gain • Setting of encoder rotation direction 	

*1 Regeneration unit (option) is necessary for regeneration

*2 With online auto tuning (adaptive magnetic flux observer), dedicated motor, rated load

7 POSITION CONTROL FUNCTION

7.1 Position control

- In the position control, the speed command given to rotate the motor is calculated to eliminate the difference between command pulse (or parameter setting) and the number of feedback pulses from the encoder.
- This option enables position control by the programmable controller positioning module.

◆ Setting procedure

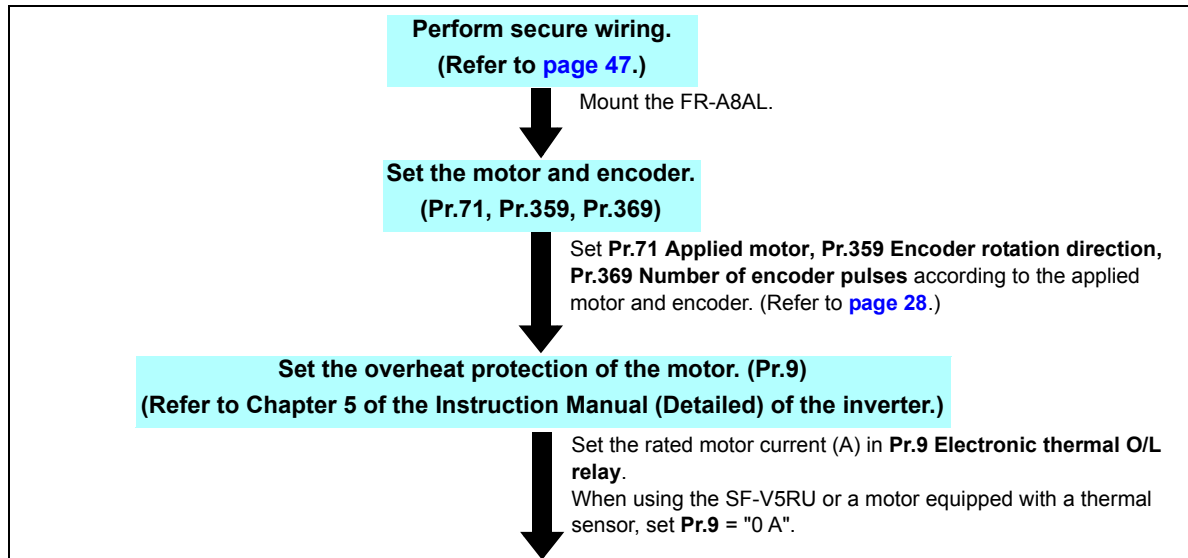

Set the motor capacity and number of motor poles. (Pr.80, Pr.81)
(Refer to Chapter 5 of the Instruction Manual (Detailed) of the inverter.)

Set the motor capacity (kW) in **Pr.80 Motor capacity**, and set the number of motor poles in **Pr.81 Number of motor poles**. (V/F control is performed when the setting is "9999" (initial value).)

Set the motor capacity and number of motor poles. (Pr.83, Pr.84)
(Refer to Chapter 5 of the Instruction Manual (Detailed) of the inverter.)

Set the rated motor voltage (V) in **Pr.83 Rated motor voltage**, and set the rated motor frequency (Hz) in **Pr.84 Rated motor frequency**.

Select the control method. (Refer to [page 52](#).)

Set **Pr.800** = "3" (position control), "4" (speed - position switching) or "5" (position - torque switching) to enable position control.

Select the position command source. (Pr.419)

Set **Pr.419** = "1" that indicates the position command by the programmable controller positioning unit.

Test run

As required

- Set the electronic gear. (**Pr.420, Pr.421, Pr.424**)
 - Set the position adjustment parameters. (**Pr.426, Pr.427, Pr.1294 to Pr.1297**)
 - Adjust the position control gain. (**Pr.422, Pr.423, Pr.425, Pr.446, Pr.828, Pr.877, Pr.880**)
- Refer to Chapter 5 of the Instruction Manual (Detailed) for details.



- The carrier frequency is limited during vector control. (Refer to Chapter 5 of the Instruction Manual (Detailed).)

7.2 Wiring example

Connection with the MELSEC-Q series QD75P positioning module

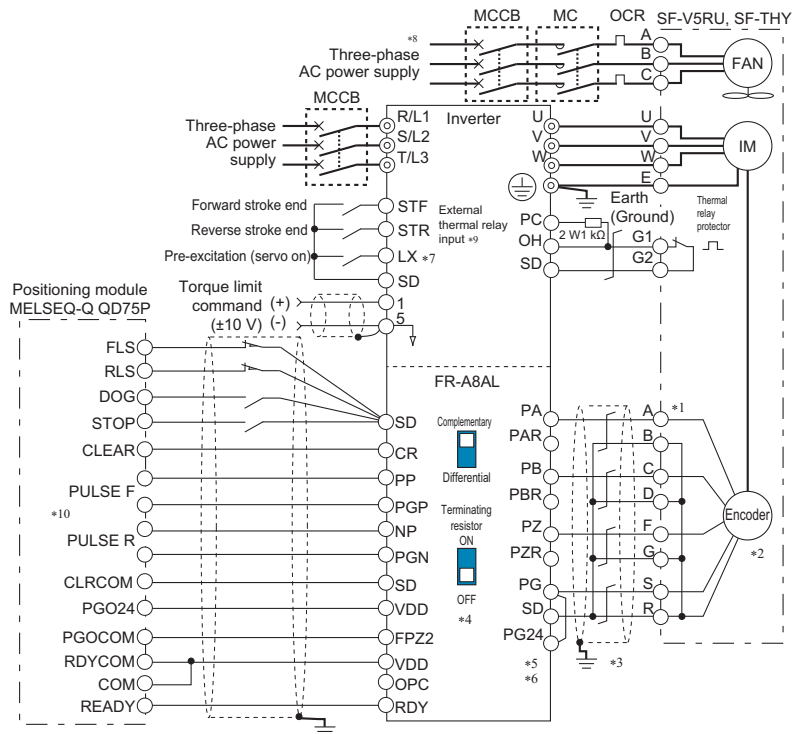

- *1 The pin number differs according to the encoder used.
Position control by pulse train input is properly performed even without connecting Z phase.
- *2 The encoder should be coupled on the same axis with the motor shaft without any mechanical looseness.
Speed ratio should be 1:1.
- *3 Earth (Ground) the shielded cable of the encoder cable to the enclosure with a P clip, etc. (Refer to [page 15](#).)
- *4 For the complementary, set the terminating resistor selection switch to OFF position (initial status) to use. (Refer to [page 13](#).)
- *5 A separate external power supply of 15 V is necessary according to the encoder power specification. When the encoder output is the differential line driver type, only 5 V can be input. If using the 24 V power supply of the FR-A8AL, the power can be supplied from terminal PG24. If using the 5 V/12 V power supply of the FR-A8AL, the power can be supplied from terminal PGV. Do not use the external power supply simultaneously with the 5 V/12 V power supply or the 24 V power supply.
Make the voltage of the external power supply the same as the encoder output voltage, and connect the external power supply between terminals PG and SD.
- *6 Refer to [page 19](#) for terminal compatibility of the FR-JCBL, FR-V7CBL and FR-A8AL.
- *7 Assign the function using **Pr.178 to Pr.189 (input terminal function selection)**.
- *8 For the fan of the 7.5 kW or lower dedicated motor, the power supply is single phase (200 V/50 Hz, 200 to 230 V/60 Hz).
- *9 To use a terminal as the terminal OH, assign the OH (external thermal O/L relay input) signal to an input terminal. (Set "7" in any of **Pr.178 to Pr.189**. For details, refer to the Instruction Manual (Detailed) of the inverter.)
- *10 Pulse signal from the positioning unit can be output by either open collector or differential line driver. Note that connection is not the same. (The figure shows the connection in case of differential line driver. Refer to terminal description on [page 21](#) for connection.)

7.3 Operation

The speed command given to rotate the motor is calculated to eliminate the difference between the number of pulse train pulses and the number of pulses feed back from the motor end encoder.

- (1) When a pulse train (MELSEC-Q series positioning module QD75P, etc.) is input, pulses are accumulated in the deviation counter and these droop pulses act as position control pulses to give the speed command.
- (2) As soon as the motor starts running under the speed command of the inverter, the encoder generates feed back pulses and the droop of the deviation counter is counted down. The deviation counter maintains a given droop pulse value to keep the motor running.
- (3) When the command pulse input stops, the droop pulses of the deviation counter decreases, reducing the speed. The motor stops when there are no droop pulses.
- (4) When the number of droop pulses has fallen below the value set in **Pr.426 In-position width**, it is regarded as completion of positioning and the in-position signal (Y36) turns on.

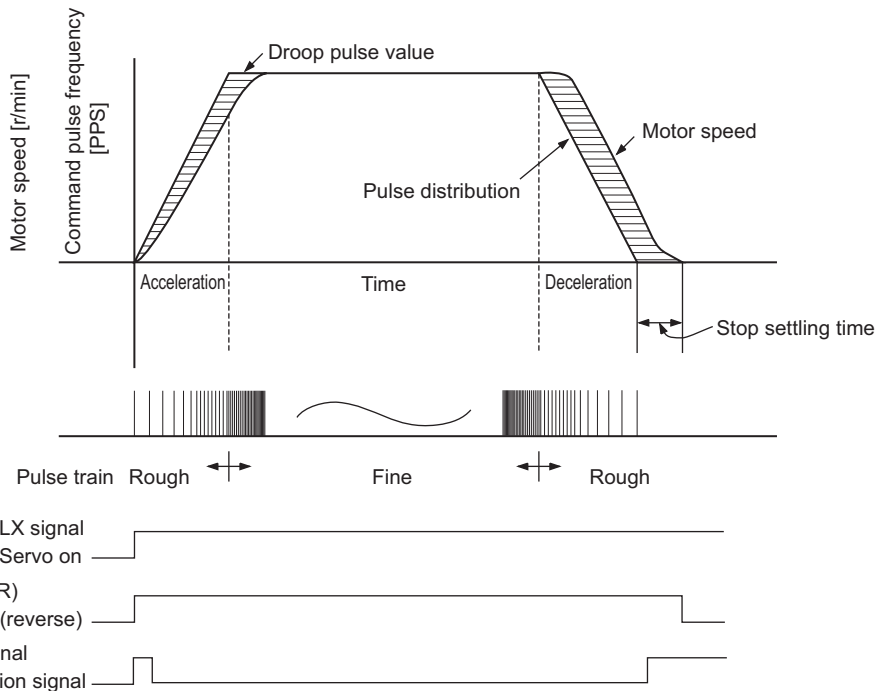

- The pulse train is rough during acceleration and fine at the maximum speed. During deceleration the pulse train is rough and at last there are no pulses. The motor stops shortly after the command pulses stop. This time lag is necessary for maintaining the stop accuracy and called stop settling time.

NOTE

- For the servo on signal (LX), set "23" in **Pr.178 to Pr.189 (input terminal function selection)** to assign the function.
- For the in-position signal (Y36), set "36" in **Pr.190 to Pr.196 (output terminal function selection)** to assign the function.

◆ Operation by position command using pulse train

Turning ON (short the terminal LX-SD) the servo on signal cancels the base circuit shut-off and operation ready signal is output after 0.1 s has passed. (Assign the servo on (LX) signal using input function selection (**Pr.178 to Pr.189**.) When the terminal STF (forward stroke end signal) or terminal STR (reverse stroke end signal) and terminal SD are shorted, the motor runs in accordance with the command pulse. When the forward (reverse) stroke end signal opens, the motor does not run in that direction.

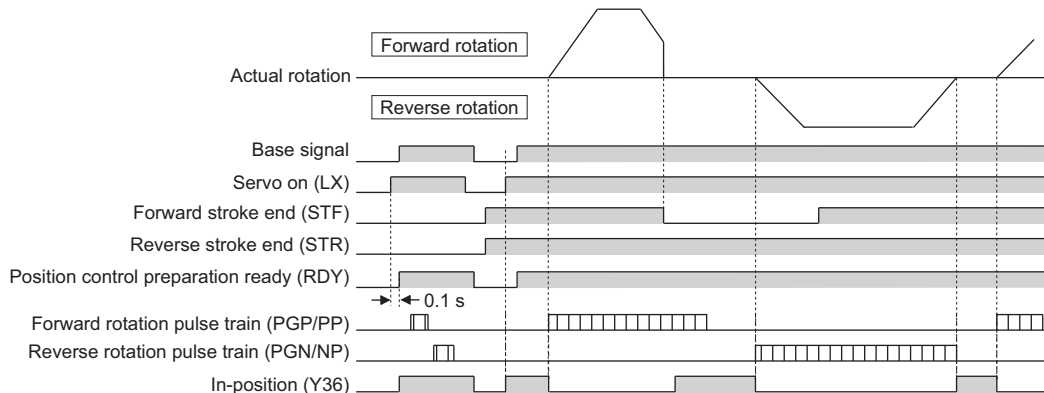

7.4 Interface of the positioning module and inverter

When running the inverter by each positioning module, interface of the positioning command pulse train need to be matched.

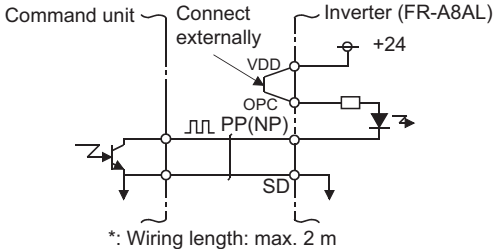
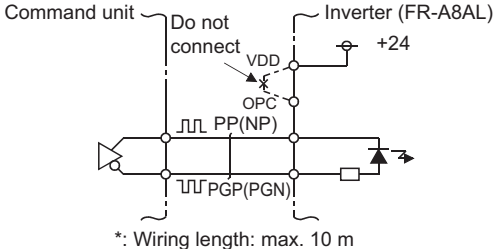
Output type	Hardware configuration	Input pulse frequency
Open collector	 <p>*: Wiring length: max. 2 m</p>	Max. 200 kpps
Differential line driver	 <p>*: Wiring length: max. 10 m</p>	Max. 500 kpps

7.5 Parameter setting and details

When performing position control with the FR-A8AL, set the following parameters.

7.5.1 Block diagram

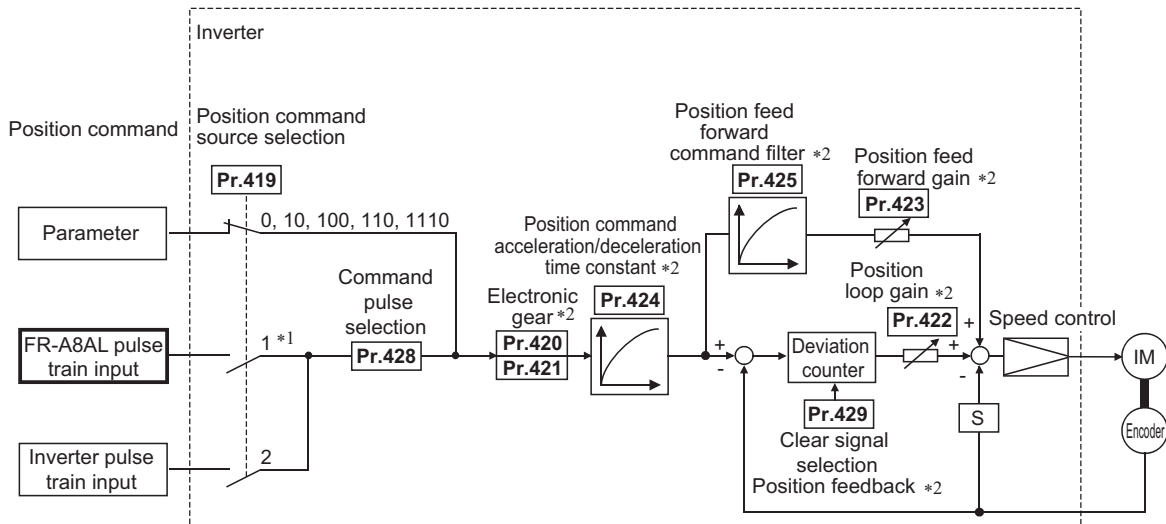

*1 When the FR-A8AL is not connected, "E.COP" is displayed.

*2 For details, refer to the Instruction Manual (Detailed) of the inverter.

7.5.2 Selection of control method (Pr.800)

Set the **Pr.800** setting to "3, 4, 5, 13, 14" to perform position control. Control circuit terminal function changes depending on parameter setting. (When the setting is "4, 5, or 14", select position control by switching MC signal.)

Terminal function changes by control mode switchover as below.

Classification	Terminal name	Description							
		Pr.800 = "3"	Pr.800 = "4"		Pr.800 = "5"		Pr.800 = "13"	Pr.800 = "14"	
		Position control	Speed control MC signal: OFF	Position control MC signal: ON	Position control MC signal: OFF	Torque control MC signal: ON	Position control	Speed control MC signal: OFF	Position control MC signal: ON
Contact input signal	STF	Forward stroke end	Forward rotation command	Forward stroke end	Forward stroke end	Forward rotation command	Forward stroke end	Forward rotation command	Forward stroke end
	STR	Reverse stroke end	Reverse rotation command	Reverse stroke end	Reverse stroke end	Reverse rotation command	Reverse stroke end	Reverse rotation command	Reverse stroke end

NOTE

- Assign MC signal to **Pr.180 to Pr.188**. Set any of **Pr.180 to Pr.188** to "26".
- For analog input terminal, function changes according to **Pr.858 Terminal 4 function assignment, Pr.868 Terminal 1 function assignment** setting. (Refer to the Instruction Manual (Detailed) of the Inverter for details.)

7.5.3 Position control

- Position command source selection (**Pr.419**)

When using the FR-A8AL, set "1" in **Pr.419**.

Pr.419 setting	Description
0 (initial value), 10, 100, 110, 1110	Simple position control by point tables (position command by setting parameters).
1	Position command by pulse train input (when the FR-A8AL is mounted).
2	Conditional pulse train position command by inverter pulse train input.

- Pulse train form (Pr.428)

Command pulse can be changed according to the positioning module as in the table below.

Command pulse train form		At forward rotation	At reverse rotation	Setting Pr.428	Remarks
Negative logic	Forward rotation pulse train Reverse rotation pulse train			0 (initial setting)	QD75D (CW/CWW mode) (Note) If (CW/CWW mode) and (PLS/SIGN mode) are misselected, the motor runs only in one direction.
	Pulse train + sign			1	QD75D (PLS/SIGN mode)
	A phase pulse train B phase pulse train			2	Counted after multiplying by four. Set the pulse train frequency multiplied by four to 500k pulses/s or less with the differential driver type and to 200k pulses/s or less with the open collector type.
Positive logic	Forward rotation pulse train Reverse rotation pulse train			3	—
	Pulse train + sign			4	—
	A phase pulse train B phase pulse train			5	Counted after being multiplied by four. Set the pulse train frequency multiplied by four to 500k pulses/s or less with the differential driver type and to 200k pulses/s or less with the open collector type.

7.5.4 Troubleshooting

No.	Condition	Cause	Countermeasure
1	Motor does not rotate	The phase sequence of the motor or encoder wiring is wrong.	Check the wiring (Refer to page 47 .)
		The control mode selection, Pr.800 , setting is improper.	Check the Pr.800 setting. (Refer to the Instruction Manual (Detailed) of the Inverter.)
		The servo on signal or stroke end signal (STF, STR) is not input.	Check that the signals are input normally.
		Command pulse, position pulse sign (NP) are not correctly input.	<ul style="list-style-type: none"> • Check that the command pulses are input normally. (Check the cumulative command pulse value in Pr.430) • Check the command pulse form and command pulse selection, Pr.428, setting.
		The Pr.419 Position command source selection , setting is not correct.	Check the position command source selection in Pr.419 .
2	Position shift occurs.	The command pulses are not input correctly.	<ul style="list-style-type: none"> • Check the command pulse form and command pulse selection, Pr.428, setting. • Check that the command pulses are input normally. (Check the cumulative command pulse value in Pr.430)
		The command is affected by noise. Or the encoder feedback signal is compounded with noise.	<ul style="list-style-type: none"> • Decrease Pr.72 PWM frequency selection. • Change the earthing (grounding) point of shielded wire. Or leave the cable suspended.
3	Motor or machine hunts.	The position loop gain is high.	Decrease the Pr.422 value.
		The speed loop gain is high.	<ul style="list-style-type: none"> • Perform easy gain tuning. • Decrease Pr.820 and increase Pr.821.
4	Machine operation is unstable	The acceleration/deceleration time setting has adverse effect.	Decrease Pr.7 and Pr.8 .
5	<ul style="list-style-type: none"> • The motor rotation speed does not increase. • Motor rotation is unstable. 	<ul style="list-style-type: none"> • Wiring of encoder is incorrect. • The encoder power supply is not connected or turned ON. 	Check the wiring.

7.6 Specifications

Repeated positioning accuracy	$\pm 1.5^\circ$ (motor shaft end) (changes according to load torque, moment of inertia J or backlash condition of the load)
Holding force after positioning	With servo lock
Power supply	24 V power supply output for interface driver is provided
Maximum input pulse frequency	Differential line receiver: 500k pulses/s, open collector: 200k pulses/s
Positioning return pulse	Number of encoder pulses per motor rotation \times 4 times
Electronic gear setting	1/50 to 20
In-position width setting	0 to 32767 pulses
Error excess	0 to 400k pulses

8 ENCODER PULSE DIVIDING OUTPUT

Pulse input of encoder connected to the inverter is divided and output from the FR-A8AL terminal.

8.1 Wiring example

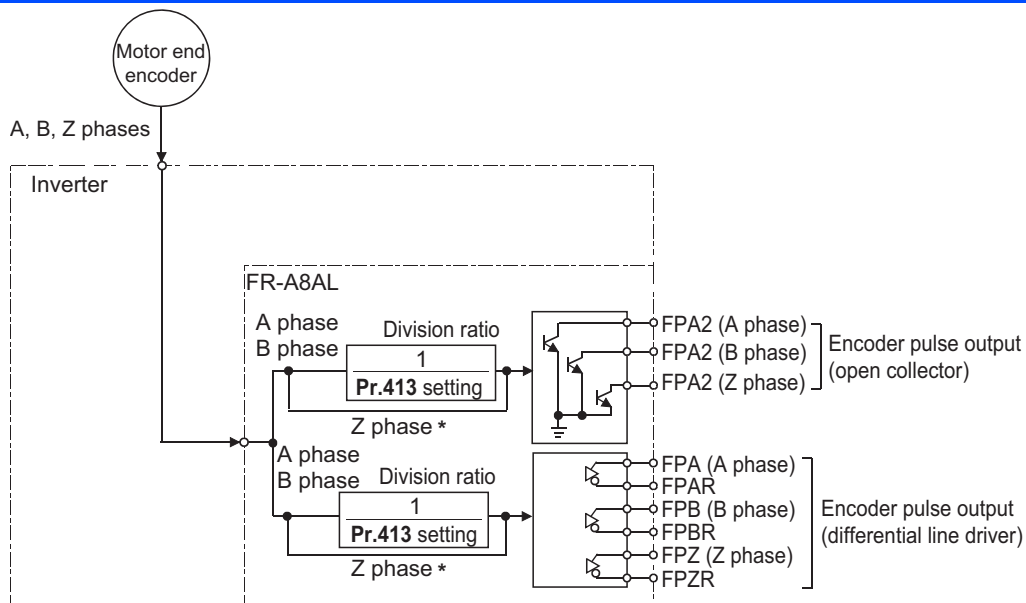

* Z phase can not be divided.

NOTE

- For open collector output, the signal may become unstable if the input resistance of the connected device is large and the device may detect the signal incorrectly. In this case, adding a pull-up resistance as shown below will improve the phenomenon.
- Select a pull-up resistance in consideration of the input current of the connected device so that the open collector output current will not exceed the output permissible load current.

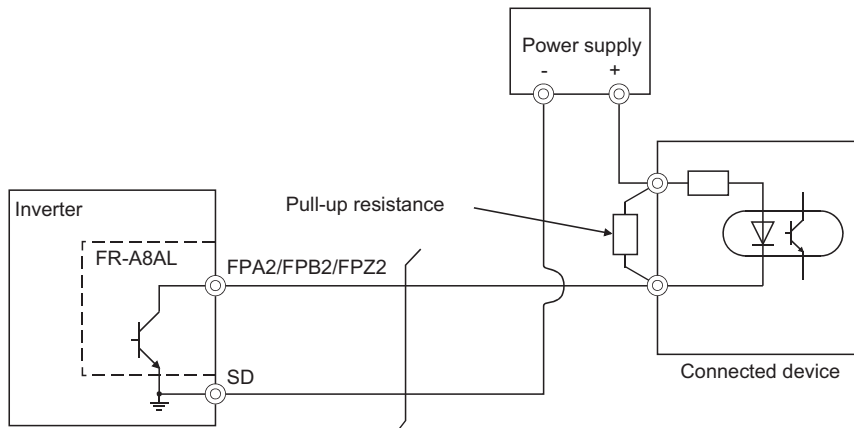

8.2 Parameter related to encoder pulse dividing output

Pr.	Pr. group	Name	Initial value	Setting range	Description
413	M601	Encoder pulse division ratio	1	1 to 32767	The encoder pulse signal at the motor end can be divided in division ratio set in Pr.413 and output. Use this parameter to make the response of the machine to be input slower, etc.

- Division waveform by division ratio
Both ON-OFF width is division times. (50% duty)
 - Pulse waveform example at 1000 pulse input when **Pr.413** = "2"

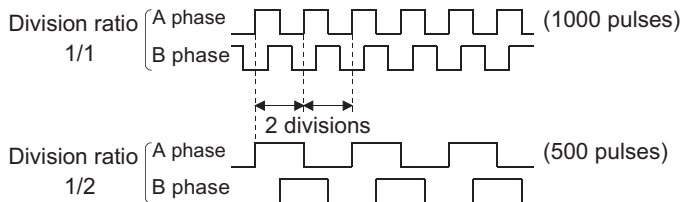

NOTE

- Control of forward rotation/reverse rotation by phase difference between A phase and B phase.
When A phase is 90° advanced as compared to B phase: forward rotation
When A phase is 90° behind as compared to B phase: reverse rotation

APPENDIX

Restricted Use of Hazardous Substances in Electronic and Electrical Products

The mark of restricted use of hazardous substances in electronic and electrical products is applied to the product as follows based on the "Management Methods for the Restriction of the Use of Hazardous Substances in Electrical and Electronic Products" of the People's Republic of China.

电器电子产品有害物质限制使用标识要求



本产品中所含有的有害物质的名称、含量、含有部件如下表所示。

- 产品中所含有害物质的名称及含量

部件名称*2	有害物质*1					
	铅 (Pb)	汞 (Hg)	镉 (Cd)	六价铬 (Cr (VI))	多溴联苯 (PBB)	多溴二苯醚 (PBDE)
电路板组件 (包括印刷电路板及其构成的零部件, 如电阻、电容、集成电路、连接器等)、电子部件	×	○	×	○	○	○
金属壳体、金属部件	×	○	○	○	○	○
树脂壳体、树脂部件	○	○	○	○	○	○
螺丝、电线	○	○	○	○	○	○

上表依据SJ/T11364的规定编制。

○：表示该有害物质在该部件所有均质材料中的含量均在GB/T26572规定的限量要求以下。

×：表示该有害物质在该部件的至少一种均质材料中的含量超出GB/T26572规定的限量要求。

*1 即使表中记载为×，根据产品型号，也可能会有有害物质的含量为限制值以下的情况。

*2 根据产品型号，一部分部件可能不包含在产品中。

MEMO

REVISIONS

*The manual number is given on the bottom left of the back cover.

Revision date	*Manual number	Revision
Jul. 2015	IB(NA)-0600597ENG-A	First edition
Sep. 2018	IB(NA)-0600597ENG-B	Addition <ul style="list-style-type: none">• Connection diagram of encoder power supply terminals• Restricted Use of Hazardous Substances in Electronic and Electrical Products



FR-A8AL Instruction Manual: Precautions for Use

Pulse train input (for the torque command and position control) is unavailable when using this option with FR-A800 inverters which have the following SERIAL.

Model	Country of origin	SERIAL / Date of manufacture
FR-A820-00046(0.4K) to 04750(90K) FR-A840-00023(0.4K) to 06830(280K) FR-A842-07700(315K) to 12120(500K) FR-A846-00023(0.4K) to 03610(132K)	MADE IN JAPAN	□ 83 ○○○○○○ to □ 86 ○○○○○○ March 2018 to June 2018
	MADE IN CHINA	□ 84 ○○○○○○ to □ 87 ○○○○○○ April 2018 to July 2018

Check the SERIAL number indicated on the inverter rating plate or package.

Rating plate example

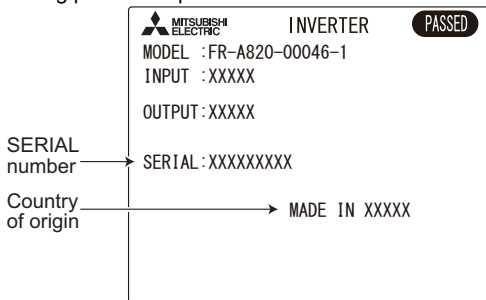

□ ○ ○ ○○○○○○
Symbol Year Month Control number

SERIAL

The SERIAL consists of one symbol, two characters indicating the production year and month, and six characters indicating the control number. The last digit of the production year is indicated as the Year, and the Month is indicated by 1 to 9, X (October), Y (November), or Z (December).

Contact your sales representative if you have any questions.

INVERTER

mitsubishi electric corporation

HEAD OFFICE: TOKYO BUILDING 2-7-3, MARUNOUCHI, CHIYODA-KU, TOKYO 100-8310, JAPAN