



INVERTER

Plug-in option

FR-A7AL

INSTRUCTION MANUAL

ORIENTATION CONTROL

ENCODER FEEDBACK CONTROL

VECTOR CONTROL

POSITION CONTROL

ENCODER PULSE DIVIDING OUTPUT

PRE-OPERATION INSTRUCTIONS

1

INSTALLATION

2

ORIENTATION CONTROL

3

ENCODER FEEDBACK CONTROL

4

VECTOR CONTROL

5

POSITION CONTROL FUNCTION

6

ENCODER PULSE DIVIDING OUTPUT

7

Thank you for choosing this Mitsubishi Inverter plug-in option. This instruction manual gives handling information and precautions for use of this equipment. Incorrect handling might cause an unexpected fault. Before using the equipment, please read this manual carefully to use the equipment to its optimum. Please forward this manual to the end user.

This section is specifically about safety matters

Do not attempt to install, operate, maintain or inspect this product until you have read through this instruction manual and appended documents carefully and can use the equipment correctly. Do not use this product until you have a full knowledge of the equipment, safety information and instructions.

In this instruction manual, the safety instruction levels are classified into "WARNING" and "CAUTION".

WARNING

Assumes that incorrect handling may cause hazardous conditions, resulting in death or severe injury.

CAUTION

Assumes that incorrect handling may cause hazardous conditions, resulting in medium or slight injury, or may cause physical damage only.

Note that even the  **CAUTION** level may lead to a serious consequence according to conditions. Please follow the instructions of both levels because they are important to personnel safety.

SAFETY INSTRUCTIONS

1. Electric Shock Prevention

WARNING

- While power is on or when the inverter is running, do not open the front cover. You may get an electric shock.
- Do not run the inverter with the front cover or wiring cover removed. Otherwise, you may access the exposed high-voltage terminals and charging part and get an electric shock.
- If power is off, do not remove the front cover except for wiring or periodic inspection. You may access the charged inverter circuits and get an electric shock.
- Before starting wiring or inspection, check to make sure that the indication of the inverter operation panel is off, wait for at least 10 minutes after the power supply has been switched off, and check that there are no residual voltage using a tester or the like. The capacitor is charged with high voltage for some time after power off and it is dangerous.
- Any person who is involved in the wiring or inspection of this equipment should be fully competent to do the work.
- Always install the plug-in option before wiring. Otherwise, you may get an electric shock or be injured.
- Do not touch the plug-in option with wet hands. Otherwise you may get an electric shock.
- Do not subject the cables to scratches, excessive stress, heavy loads or pinching. Otherwise you may get an electric shock.

2. Injury Prevention

CAUTION

- Apply only the voltage specified in the instruction manual to each terminal. Otherwise, burst, damage, etc. may occur.
- Ensure that the cables are connected to the correct terminals. Otherwise, burst, damage, etc. may occur.
- Always make sure that polarity is correct to prevent damage, etc. Otherwise, burst, damage may occur.
- While power is on or for some time after power-off, do not touch the inverter as it is hot and you may get burnt.

3. Additional Instructions

Also note the following points to prevent an accidental failure, injury, electric shock, etc.

1) Transportation and mounting

CAUTION

- Do not install or operate the plug-in option if it is damaged or has parts missing.
- Do not stand or rest heavy objects on the product.
- Check that the mounting orientation is correct.
- Prevent other conductive bodies such as screws and metal fragments or other flammable substance such as oil from entering the inverter.

2) Trial run

CAUTION

- Before starting operation, confirm and adjust the parameters. A failure to do so may cause some machines to make unexpected motions.

3) Usage

WARNING

- Do not modify the equipment.
- Do not perform parts removal which is not instructed in this manual. Doing so may lead to fault or damage of the inverter.

CAUTION

- When parameter clear or all parameter clear is performed, reset the required parameters before starting operations. Each parameter returns to the initial value.
- For prevention of damage due to static electricity, touch nearby metal before touching this product to eliminate static electricity from your body.

4) Maintenance, inspection and parts replacement

CAUTION

- Do not test the equipment with a megger (measure insulation resistance).

5) Disposal

CAUTION

- Treat as industrial waste.

6) General instruction

All illustrations given in this manual may have been drawn with covers or safety guards removed to provide in-depth description. Before starting operation of the product, always return the covers and guards into original positions as specified and operate the equipment in accordance with the manual.

— CONTENTS —

1	PRE-OPERATION INSTRUCTIONS	1
1.1	Unpacking and Product Confirmation	1
1.1.1	Packing confirmation	1
1.1.2	SERIAL number check	2
1.2	Parts	3
1.3	Terminal Specifications	5
2	INSTALLATION	8
2.1	Pre-Installation Instructions	8
2.2	Installation Procedure	9
2.3	Encoder Specifications/Terminating Resistor Switch	11
2.4	Wiring	13
2.5	Encoder Cable	18
2.6	Encoder	20
2.7	Parameters for Encoder	22
3	ORIENTATION CONTROL	24
3.1	Wiring Example	24
3.2	Terminals	26
3.3	Orientation Control Parameter List	29
3.4	Specifications	30

4	ENCODER FEEDBACK CONTROL	31
4.1	Wiring Example	31
4.2	Terminals	33
4.3	Encoder Feedback Control Parameter List	34
5	VECTOR CONTROL	35
5.1	Wiring Example	36
5.2	Terminals	40
5.3	Vector Control Extended Parameter List	41
5.4	Pulse Train Torque Command	45
5.4.1	Parameter list	45
5.4.2	Pulse train torque command	45
5.5	Specifications	46
6	POSITION CONTROL FUNCTION	47
6.1	Position Control by Vector Control	47
6.1.1	Position control	47
6.2	Wiring Example	50
6.3	Terminals	52
6.4	Operation	53
6.4.1	Operation by position command using pulse train	55
6.4.2	Initial setting	56
6.4.3	Setting the electronic gear (Pr. 420, Pr. 421, Pr. 424)	56

6.5	Pulse Input Type	62
6.6	Interface of the Positioning Unit and Inverter	64
6.7	Extended Function Parameter List.....	65
6.8	Parameter Setting and Details	66
6.8.1	Block diagram.....	66
6.8.2	Selection of control method (<i>Pr. 800</i>).....	67
6.8.3	Position control	69
6.8.4	Gain adjustment of position control (<i>Pr. 422, Pr. 423, Pr. 425</i>).....	71
6.8.5	Selection of clear signal (<i>Pr. 429, CR signal</i>)	73
6.8.6	Troubleshooting.....	74
6.9	Specifications.....	76
7	ENCODER PULSE DIVIDING OUTPUT	77
7.1	Wiring Example	77
7.2	Terminals	79
7.3	Encoder.....	81

1 PRE-OPERATION INSTRUCTIONS



1.1 Unpacking and Product Confirmation

Take the plug-in option out of the package, check the product name, and confirm that the product is as you ordered and intact.

This product is a plug-in option unit dedicated for the FR-A700 series.

1.1.1 Packing confirmation

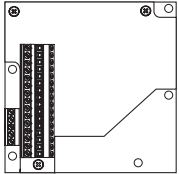
Check the enclosed items.

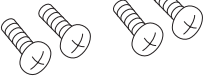
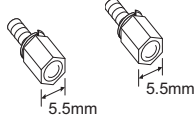
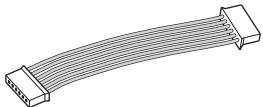
<p>Plug-in option 1</p> 	<p>Instruction manual 1</p> 	<p>Mounting screws (M3×6mm) 4 (Refer to page 9)</p> 	<p>Hex-head screw for option mounting (5.5mm) 2 (Refer to page 9)</p> 
<p>FR-A7NS connection cable 1 (Refer to page 10)</p> 			

1.1.2 SERIAL number check

The FR-A7AL can be used with the FR-A700 series assembled in and after October 2007. Check the SERIAL number indicated on the inverter rating plate or package.

Rating plate example

<u>□</u>	<u>7</u>	<u>X</u>	<u>○○○○○○</u>
Symbol	Year	Month	Control number
<hr/>			
SERIAL number			

The SERIAL consists of 1 version symbol, 2 numeric characters or 1 numeric character and 1 alphabet letter indicating year and month, and 6 numeric characters indicating control number.

Month is indicated as 1 to 9, X (October), Y (November), and Z (December).

1.2 Parts

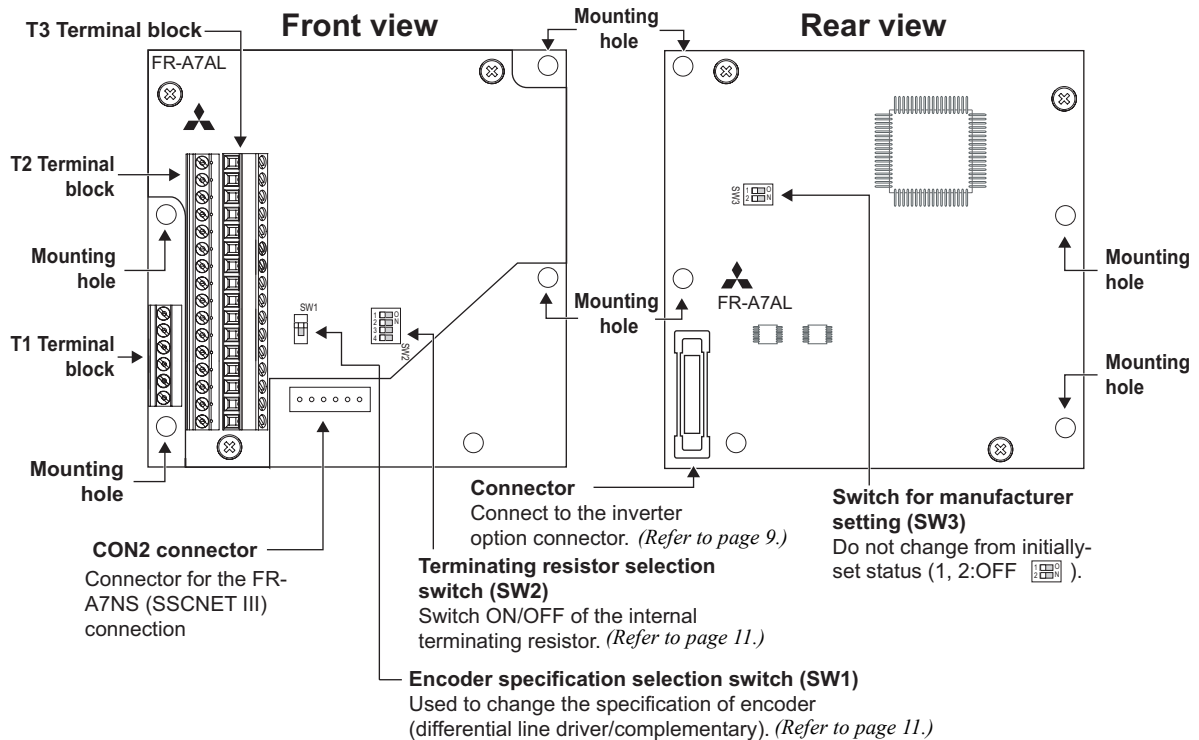

1

Terminal layout

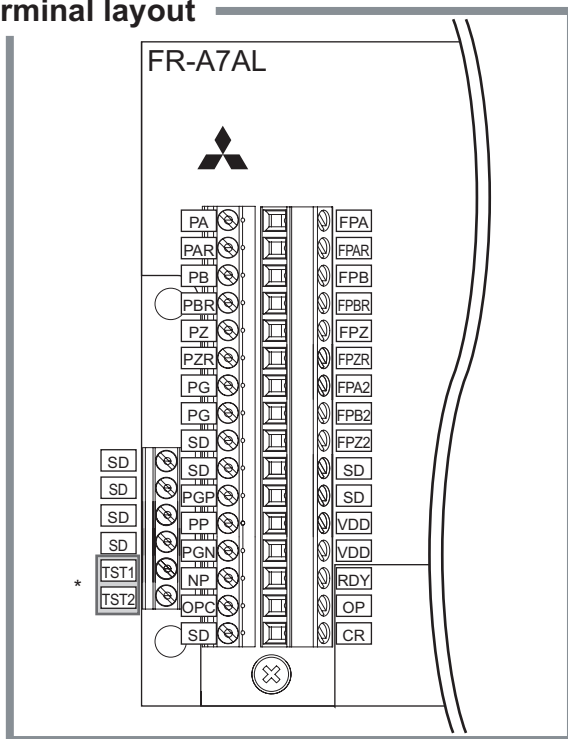

* Terminal TST1, TST2 are not used. Keep these open. Accidental connection will damage the option.

1.3 Terminal Specifications

Function	Terminal Symbol	Terminal (Signal) Name	Specification	Description	
Position control function	PGP PP	Forward rotation pulse train	Open collector/ differential line driver	Forward rotation pulse train input terminal	For open collector, connect terminal VDD and OPC, then input pulses across terminal PP-SD and NP-SD. For differential line driver, open terminal OPC, then input pulse across terminal PP-PGP and NP-PGN.
	PGN NP	Reverse rotation pulse train		Reverse rotation pulse train input terminal	
	CR	Clear	—	Shortning terminal CR-SD clears counter at the rising edge.	
	OPC	Open collector power input	24VDC	When inputting pulse by open collector method, connect this terminal to terminal VDD (24V power supply)	
	SD	Contact input common	—	Contact input common terminal. Do not earth (ground).	
	VDD	Driver power supply	24VDC	Driver power supply terminal for interface	
	RDY	Preparation ready signal	—	When servo ON and ready to drive, the signal is output.	
	OP	Encoder Z-phase output	Open collector output permissible load 24VDC, max. 50mA	Outputs one pulse per motor revolution.	

Function	Terminal Symbol	Terminal (Signal) Name	Specification	Description
Encoder pulse input	PA	Encoder A-phase signal input	Differential line driver/ complementary	A-, B- and Z-phase signals are input from the encoder.
	PAR	Encoder A-phase inverse signal input		
	PB	Encoder B-phase signal input		
	PBR	Encoder B-phase inverse signal input		
	PZ	Encoder Z-phase signal input		
	PZR	Encoder Z-phase inverse signal input		
	PG	Power supply (positive side) input		Input power for the encoder power supply. Connect the external power supply (5V, 12V, 15V, 24V) and the power cable from encoder.
	SD	Power ground		



Function	Terminal Symbol	Terminal (Signal) Name	Specification	Description	
Encoder pulse division output	Open collector	FPA2	Encoder A-phase signal output	Open collector output Permissible load 24VDC max. 50mA	Outputs the A-phase, B-phase and Z-phase (origin and mark pulse) signals from the encoder. The A-phase and B-phase signals can be divided by the ratio (1/n) and output. n=1 to 32767 (integer). Set using <i>Pr.413 Encoder pulse division ratio</i> . Common terminal is terminal SD.
		FPB2	Encoder B-phase signal output		
		FPZ2	Encoder Z-phase signal output		
	Differential line driver	FPA	Encoder differential A-phase signal output	Differential line driver output Permissible load 0.1A	Outputs the A-phase, B-phase and Z-phase (origin and mark pulse) signals from the encoder. The A-phase and B-phase signals can be divided by the ratio (1/n) and output. n=1 to 32767 (integer). Set using <i>Pr.413 Encoder pulse division ratio</i> .
		FPAR	Encoder differential A-phase inverse signal output		
		FPB	Encoder differential B-phase signal output		
		FPBR	Encoder differential B-phase inverse signal output		
		FPZ	Encoder differential Z-phase signal output		
		FPZR	Encoder differential Z-phase inverse signal output		

2 INSTALLATION

2.1 Pre-Installation Instructions

Make sure that the input power of the inverter is off.

CAUTION

-  Do not install or remove a plug-in option while input power is on. Otherwise, the inverter and option may be damaged.
-  For prevention of damage due to static electricity, touch nearby metal before touching this product to eliminate static electricity from your body.

2.2 Installation Procedure

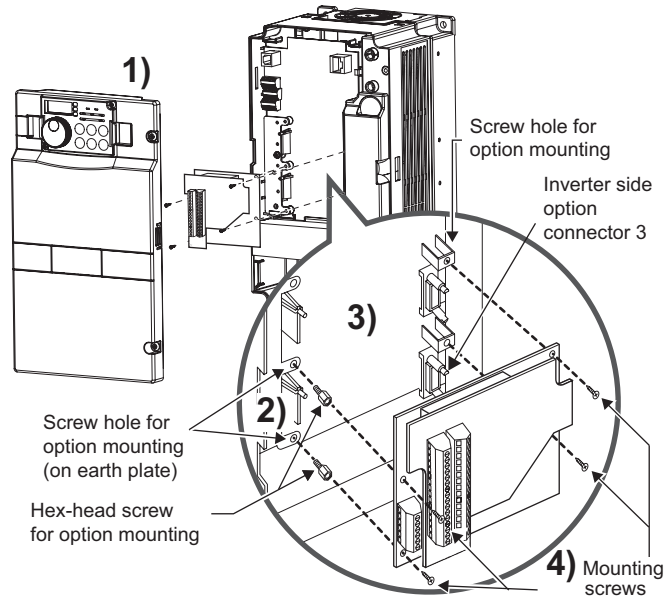

- 1) Remove the inverter front cover.
- 2) This option can be fitted to either option connector 2 or 3. (The left diagram shows that the option is fitted to connector 3) Mount the hex-head screw for option mounting into the inverter screw hole (on earth plate). (size 5.5mm, tightening torque 0.56N · m to 0.75N · m)
- 3) Securely fit the connector of the plug-in option to the inverter connector along the guides. Occupies space equivalent to two option units.
- 4) Fix four places on both right and left sides of the plug-in option unit to the inverter securely with the accessory mounting screws. (Tightening torque: 0.45N·m to 0.55N·m) If the screw holes do not line-up, the connector may not have been plugged snugly. Check for loose plugging.

REMARKS

Remove a plug-in option after removing four screws on both left and right sides.
 (When the plug-in option is mounted in the connector 3, it is easier to remove the plug-in option after removing a control circuit terminal block.)

There are three connection connectors for the plug-in option at the inverter and they are called CON. 1, CON. 2, and CON. 3 from above.

The FR-A7AL can be fitted to CON. 2 or CON. 3.

CAUTION

- The FR-A7AL requires space equivalent to two option units, only one option can be used at the time. For other option units, mount it to the option CON. 1 or CON. 3. It can not be connected to the option CON. 2.
- When both the FR-A7AL and FR-A7AP are fitted, the FR-A7AP function will be made invalid.
- When the inverter cannot recognize that the option is mounted due to improper installation, etc., "E. 1 to E. 3" (option alarm) are displayed. The errors shown differ according to the mounting positions (CON. 1, 2, 3).

Fitting Position	Error Display
Connector 1 (CON. 1)	E. 1
Connector 2 (CON. 2)	E. 2
Connector 3 (CON. 3)	E. 3

- When using the FR-A7AL and FR-A7NS together, fit the FR-A7AL at option CON. 2 and the FR-A7NS at option CON. 3.

After fitting both the FR-A7AL and FR-A7NS, connect each external connector with a connection cable (refer to page 1) packed with the FR-A7AL.

(Do not use the FR-A7AP connection cable enclosed with the FR-A7NS.)

- Take care not to drop a hex-head screw for option mounting or mounting screws may drop during mounting and removal.
- Pull out the option straight to remove. Otherwise, the connector may be damaged.

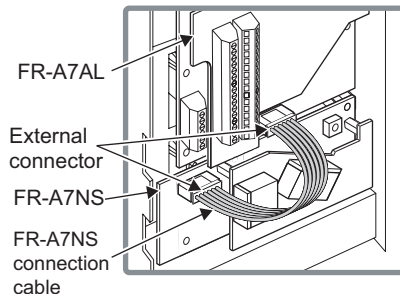

2.3 Encoder Specifications/Terminating Resistor Switch

- (1) Encoder specification selection switch (SW1)
 Select either differential line driver or complementary.
 The connector is fitted to complimentary in the initial setting. Switch its position according to output circuit.

Complementary
(initial setting)

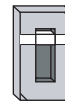

Differential line driver

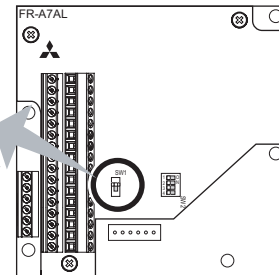

- (2) Terminating resistor selection switch (SW2)
 Select ON/OFF of the internal terminating resistor.
 Set the switch to OFF (initial status) when an encoder output type is complimentary. Set the switch to ON when an encoder type is differential line driver.
 ON : with internal terminating resistor
 OFF : without internal terminating resistor (initial setting)

Internal terminating
resistor-OFF
(initial setting)

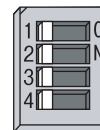

Internal terminating
resistor-ON

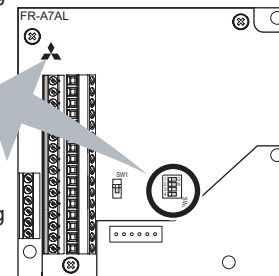

2

REMARKS

- Set all switches to the same setting (ON/OFF).
- If the encoder output type is differential line driver, set the terminating resistor switch to the "OFF" position when sharing the same encoder with other unit (CNC (computer numerical control), etc) and a terminating resistor is connected to other unit.

(3) Motor used and switch setting

Motor		Encoder Specification Switch (SW1)	Terminating Resistor Switch (SW2)	Power Specifications *2
Mitsubishi standard motor with encoder	SF-JR	Differential	ON	5V
	SF-HR	Differential	ON	5V
Mitsubishi high efficiency motor with encoder	Others	*1	*1	*1
Mitsubishi constant torque motor with encoder	SF-JRCA	Differential	ON	5V
	SF-HRCA	Differential	ON	5V
	Others	*1	*1	*1
Vector dedicated motor	SF-V5RU	Complimentary	OFF	12V
Other manufacturer's motor with encoder		*1	*1	*1

*1 Set according to the motor (encoder) used.

*2 Choose a power supply (5V/12V/15V/24V) for encoder according to the encoder.

CAUTION

Switch "SW3" is for manufacturer setting. Do not change the setting.

2.4 Wiring

- (1) Use twisted pair shield cables (0.2mm² or larger) to connect the FR-A7AL. Cables to terminals PG and SD should be connected in parallel or be larger in size according to the cable length. To protect the cables from noise, run them away from any source of noise (e.g. the main circuit and power voltage).

Wiring Length	Parallel Connection		Larger-size Cable
Within 10m	At least two cables in parallel	Cable gauge 0.2mm ²	0.4mm ² or larger
Within 20m	At least four cables in parallel		0.75mm ² or larger
Within 100m*	At least six cables in parallel		1.25mm ² or larger

* When encoder type is differential line driver and a wiring length is 30m or more

Use a power supply slightly higher than 5V (approximately 5.5V) in addition to 6 or more parallel cables of 0.2mm² or cables of 1.25mm² or more. Note that the voltage applied should be within power supply specifications of encoder.

To reduce noise of the encoder cable, earth (ground) the encoder shielded cable to the enclosure (as near as the inverter) with a P clip or U clip made of metal.

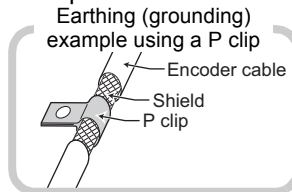

REMARKS

- For details of the dedicated encoder cable (FR-JCBL/FR-V7CBL), refer to page 18.
- The FR-V7CBL is provided with a P clip for earthing (grounding) shielded cable.

7 INSTALLATION

(2) Connection with CNC (computer numerical control)

When one position detector is shared between the FR-A7AL and CNC, its output signal should be connected as shown at the right figure. In this case, the wiring length between the FR-A7AL and CNC should be as short as possible (within 5m).

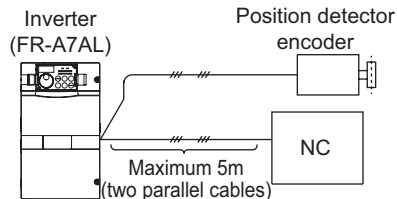

(3) Strip sheath of a twisted pair shield cables and untwist its cables for wiring.

Also, perform terminal treatment of the shield to ensure that it will not make contact with the conductive area.

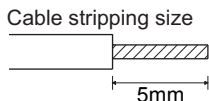

Wire the stripped cable after twisting it to prevent it from becoming loose. In addition, do not solder it. Use a bar terminal as necessary.

REMARKS

•Information on bar terminals...recommended product (as of September, 2006)

Terminal Screw Size	Cable Size (mm ²)	Bar Terminal Model		Maker
		With insulation sleeve	Without insulation sleeve	
M2	0.3 to 0.5	AI 0,5-6WH	A 0,5-6	Phoenix Contact Co.,Ltd.

Bar terminal crimping tool: CRIMPFOX ZA3 (Phoenix Contact Co., Ltd.)

When using the bar terminal (without insulation sleeve), use care so that the twisted wires do not come out.

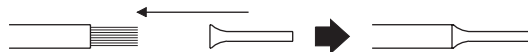



(4) Loosen the terminal screw and insert the cable into the terminal.

Screw Size	Tightening Torque	Cable Size	Screwdriver
M2	0.22N · m to 0.25N · m	0.3mm ² to 0.75mm ²	Small ⊖ flathead screwdriver (Tip thickness: 0.4mm /tip width: 2.5mm)

CAUTION

Undertightening can cause cable disconnection or malfunction. Overtightening can cause a short circuit or malfunction due to damage to the screw or unit.

7 INSTALLATION

- (5) **For wiring of the 22K* or less**, remove a hook of the front cover and use a space become available.
For wiring of the 30K* or more, use the space on the left side of the control circuit terminal block.

*The inverter type of 22K and 30K in each -NA, -EC versions are as follows.

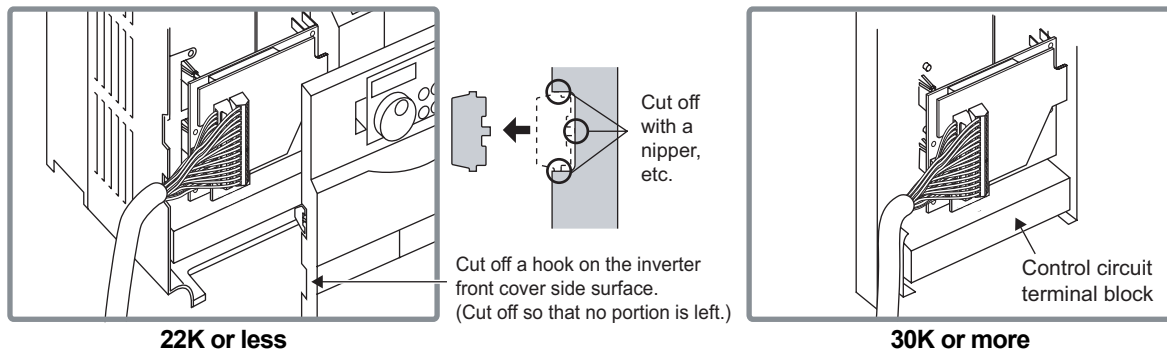



		NA	EC
A700	FR-A720-22K	FR-A720-00900-NA	—
	FR-A740-22K	FR-A740-00440-NA (FR-A760-00330-NA)	FR-A740-00620-EC
	FR-A720-30K	FR-A720-01150-NA	—
	FR-A740-30K	FR-A740-00570-NA (FR-A760-00550-NA)	FR-A740-00770-EC

REMARKS

- When the hook of the inverter front cover is cut off for wiring, the protective structure (JEM1030) changes to open type (IP00).

**CAUTION**

-  **Do not use empty terminals as junction terminals because they are used in the option unit. If they are used as the junction terminals, the option unit may be damaged.**
-  **When performing wiring using the space between the inverter front cover and control circuit terminal block, take care not to subject the cable to stress.**
-  **During wiring, do not leave wire offcuts in the inverter. They may cause a fault, failure or malfunction.**

2.5 Encoder Cable

SF-JR/HR/JRCA/HRCA with Encoder

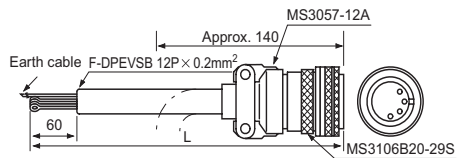

Model	Length L (m)
FR-JCBL5	5
FR-JCBL15	15
FR-JCBL30	30

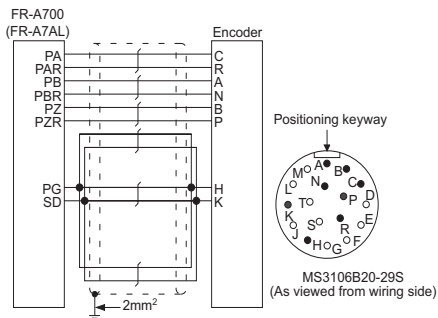

SF-V5RU, SF-THY

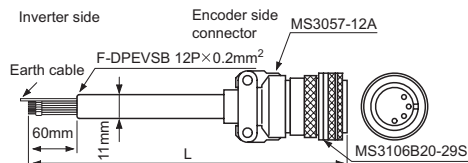

- A P clip for earthing (grounding) a shielded cable is provided.

Model	Length L (m)
FR-V7CBL5	5
FR-V7CBL15	15
FR-V7CBL30	30

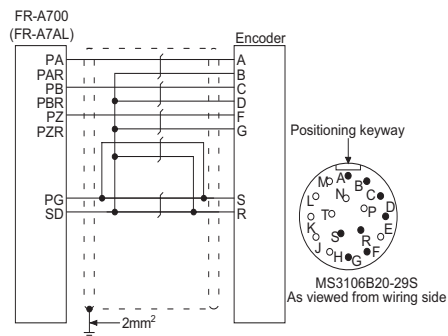

* As the terminal block of the FR-A7AL is an insertion type, earth cables need to be modified. (Refer to page 14)

Connection terminal compatibility table

Motor		SF-V5RU, SF-THY	SF-JR/HR/JRCA/HRCA (with encoder)
Encoder cable		FR-V7CBL	FR-JCBL
FR-A7AL terminal	PA	PA	PA
	PAR	Keep this open.	PAR
	PB	PB	PB
	PBR	Keep this open.	PBR
	PZ	PZ	PZ
	PZR	Keep this open.	PZR
	PG	PG	5E
	SD	SD	AG2

2.6 Encoder

(1) Position detection (pulse encoder)

Output pulse specifications

Differential line driver

A/ \bar{A} signal 1000P/R to 4096P/R

B/ \bar{B} signal 1000P/R to 4096P/R

Z/ \bar{Z} signal 1P/R

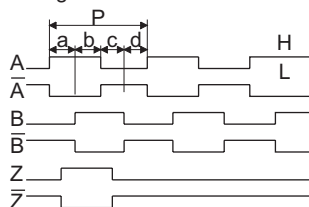

Complimentary

A signal 1000P/R to 4096P/R

B signal 1000P/R to 4096P/R

Z signal 1P/R

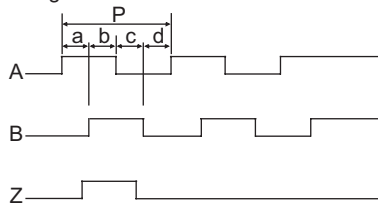

Position detector
encoder

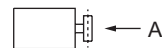

- When rotation is clockwise as viewed from the shaft end (A) of the encoder.
- a, b, c, d should be $(1/4 \pm 1/8)P$

CAUTION

- When orientation control, encoder feedback control, and vector control are used, an encoder is shared. Use the encoder with a number of pulses of 1000 to 4096ppr.
- The encoder should be coupled with the motor shaft or main spindle oriented with a speed ratio of 1 to 1 without any mechanical looseness.
- To ensure correct operation, the encoder must be set in the proper rotation direction and the A and B phases connected correctly.

(2) Power supply

Choose a power supply for encoder according to the encoder specifications.

- Specification of encoders used with Mitsubishi motors

Item	Encoder for SF-JR/HR/JRCA/HRCA	Encoder for SF-V5RU and SF-THY
Resolution	1024 pulse/rev	2048 pulse/rev
Power supply voltage	5VDC \pm 10%	12VDC \pm 10%
Current consumption	150mA	150mA
Output signal form	A, B phases (90° phase shift) Z-phase: 1 pulse/rev	A, B phases (90° phase shift) Z-phase: 1 pulse/rev
Output circuit	Differential line driver 74LS113 equivalent	Complimentary
Output voltage	"H" level 2.4V or more "L" level 0.5V or less	"H" level (-3V of the power supply voltage for encoder) or more "L" level 3V or less

2.7 Parameters for Encoder

- Parameter setting for encoder used with motor

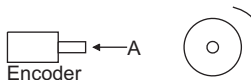
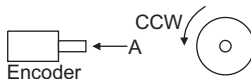
Parameter Number	Name	Initial Value	Setting Range	Description
359	Encoder rotation direction	1	0	 <p>Forward rotation is clockwise rotation when viewed from A.</p>
			1	 <p>Forward rotation is counterclockwise rotation when viewed from A.</p>
369	Number of encoder pulses	1024	0 to 4096	Set the number of pulses of the encoder. Set the number of pulses before multiplied by four.



Motor Name		<i>Pr. 359 Encoder rotation direction</i>	<i>Pr. 369 Number of encoder pulses</i>
Mitsubishi standard motor	SF-JR	1	1024
	SF-JR 4P 1.5kW or less	1	1024
	SF-HR	1	1024
	Others	*	*
Mitsubishi constant-torque motor	SF-JRCA 4P	1	1024
	SF-HRCA 4P	1	1024
	Others	*	*
Vector dedicated motor	SF-V5RU 1500r/min series	1	2048
	SF-THY	1	2048
Other manufacturer's standard motor	—	*	*
Other manufacturer's constant-torque motor	—	*	*

Values in are initial values.

* Set this parameter according to the motor used.

3 ORIENTATION CONTROL

This function is used with a position detector (encoder) installed to the spindle of a machine tool, etc. to allow a rotation shaft to be stopped at the specified position (oriented).

3.1 Wiring Example

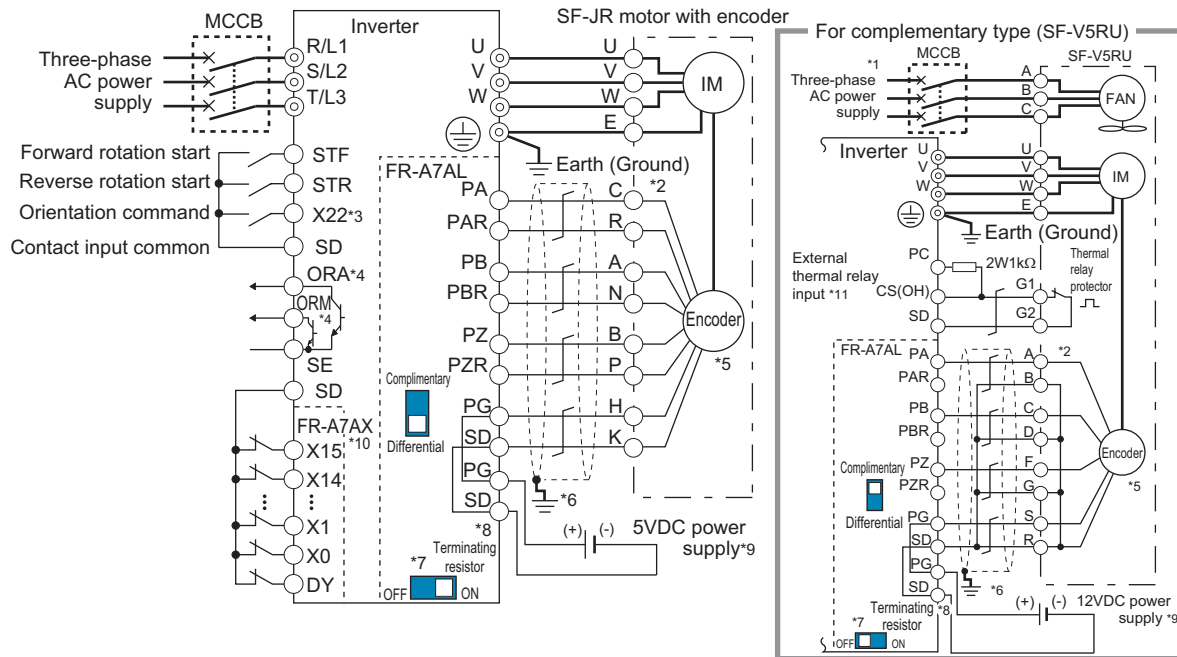

- *1 For the fan of the 7.5kW or less dedicated motor, the power supply is single phase (200V/50Hz, 200 to 230V/60Hz).
- *2 The pin number differs according to the encoder used.
- *3 Assign the function using *Pr. 178 to Pr. 189 (input terminal function selection)*.
Refer to *the inverter manual for details of Pr. 178 to Pr. 189 (input terminal function selection)*.
- *4 Assign the function using *Pr. 190 to Pr. 196 (output terminal function selection)*.
Refer to *the inverter manual for details of Pr. 190 to Pr. 196 (output terminal function selection)*.
- *5 The encoder should be coupled on the same axis with the motor shaft without any mechanical looseness.
Speed ratio should be 1:1.
- *6 Earth (Ground) the shielded cable of the encoder cable to the enclosure with a P clip, etc. (*Refer to page 13*)
- *7 For the differential line driver, set the terminating resistor selection switch to on position. (*Refer to page 11*)
Note that the terminating resistor switch should be set to off position (initial status) when sharing the same encoder with other unit (NC, etc) and a terminating resistor is connected to other unit.
For the complementary, set the terminating resistor switch to off position (initial status).
- *8 Refer to *page 19* for terminal compatibility of the FR-JCBL, FR-V7CBL and FR-A7AL.
- *9 A separate power supply of 5V/12V/15V/24V is necessary according to the encoder power specification.
When performing encoder feedback control and vector control together, an encoder and power supply can be shared.
- *10 When a stop position command is input from outside, a plug-in option FR-A7AX is necessary.
Refer to the inverter manual for details of external stop position command.
- *11 Assign OH (external thermal input) signal to the terminal CS. (Set "7" in *Pr. 186*.)
Connect a 2W1kΩ resistor between the terminal PC and CS (CH).
Install the resistor pushing it against the bottom part of the terminal block so as to avoid a contact with other cables.

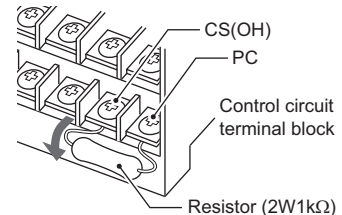

3.2 Terminals

(1) Option FR-A7AL terminal

Terminal Symbol	Terminal Name	Description
PA	Encoder A-phase signal input	A-, B- and Z-phase signals are input from the encoder. (For details of pulse signal, <i>refer to page 20.</i>)
PAR	Encoder A-phase inverse signal input	
PB	Encoder B-phase signal input	
PBR	Encoder B-phase inverse signal input	
PZ	Encoder Z-phase signal input	
PZR	Encoder Z-phase inverse signal input	
PG	Power supply (positive side) input	Input power for the encoder power supply. Connect the external power supply (5V, 12V, 15V, 24V) and the power cable from encoder.
SD	Power ground	

(2) Option FR-A7AX terminal

Terminal Symbol	Terminal Name	Description
X0 to X15	Digital signal input	Input the digital signal at the relay contact or open collector terminal. Using <i>Pr. 360</i> , speed or position command is selected as the command signal entered.
DY	Data read timing input signal	Used when a digital signal read timing signal is necessary. Data is read only during the DY signal is on. By switching the DY signal off, the X0 to X15 data before signal-off can be retained.
SD (inverter)	Common (sink)	Common terminal for digital and data read timing signals. Use terminal SD of the inverter.
PC (inverter)	External transistor common (source)	When connecting the transistor output (open collector output), such as a programmable controller, connect the external power common (+) to this terminal to prevent a fault occurring due to leakage current.

(3) Inverter terminal

Terminal (Signal)	Terminal (Signal) Name	Description
Input	X22	Orientation command input signal Used to enter an orientation signal for orientation. For the terminal used for X22 signal input, set "22" in any of <i>Pr. 178 to Pr. 189</i> to assign the function. *
	SD	Contact input common Common terminal for the orientation signal.
Output	ORA	Orientation completion signal output signal Switched low if the orientation has stopped within the in-position zone while the start and orientation signals are input. For the terminal used for the ORA signal output, assign the function by setting "27 (positive logic) or 127 (negative logic)" in any of <i>Pr. 190 to Pr. 196</i> . *
	ORM	Orientation fault signal output signal Switched low if the orientation has not stopped within the in-position zone while the start and orientation signals are input. For the terminal used for the ORM signal output, assign the function by setting "28 (positive logic) or 128 (negative logic)" in any of <i>Pr. 190 to Pr. 196</i> . *
	SE	Open collector output common Common terminal for the ORA and ORM open collector output terminals.

* Refer to the inverter manual for details of *Pr. 178 to Pr. 189* (input terminal function selection).

3.3 Orientation Control Parameter List

The following parameters for orientation control are available when used with the FR-A7AL. Refer to *the inverter manual for details of parameter.*

Parameter Number	Name	Setting Range	Increments	Initial Value
350	Stop position command selection	0, 1, 9999	1	9999
351	Orientation speed	0 to 30Hz	0.01Hz	2Hz
352	Creep speed	0 to 10Hz	0.01Hz	0.5Hz
353	Creep switchover position	0 to 16383 *	1	511
354	Position loop switchover position	0 to 8191	1	96
355	DC injection brake start position	0 to 255	1	5
356	Internal stop position command	0 to 16383 *	1	0
357	Orientation in-position zone	0 to 255	1	5
358	Servo torque selection	0 to 13	1	1
359	Encoder rotation direction	0, 1	1	1
360	16 bit data selection	0 to 127	1	0
361	Position shift	0 to 16383 *	1	0
362	Orientation position loop gain	0.1 to 100	0.1	1
363	Completion signal output delay time	0 to 5s	0.1s	0.5s
364	Encoder stop check time	0 to 5s	0.1s	0.5s
365	Orientation limit	0 to 60s, 9999	1s	9999
366	Recheck time	0 to 5s, 9999	0.1s	9999
369	Number of encoder pulses	0 to 4096	1	1024
376	Encoder signal loss detection enable/disable selection	0, 1	1	0
393	Orientation selection	0, 1, 2	1	0
396	Orientation speed gain (P term)	0 to 1000	1	60
397	Orientation speed integral time	0 to 20s	0.001	0.333
398	Orientation speed gain (D term)	0 to 100	0.1	1
399	Orientation deceleration ratio	0 to 1000	1	20

* When an operation panel (FR-DU07) is used, the maximum setting is 9999. When a parameter unit is used, up to the maximum value within the setting range can be set.

3.4 Specifications

Repeated positioning accuracy	$\pm 1.5^\circ$ Depends on the load torque, moment of inertia of the load or orientation, creep speed, position loop switching position, etc.
Permissible speed	Encoder-mounted shaft speed (6000r/min with 2048 pulse encoder) The motor and encoder-mounted shaft must be coupled directly or via a belt without any slip. It can not be applied to a gear change type.
Function	Orientation, creep speed setting, stop position command selection, DC injection brake start position setting, creep speed and position loop switch position setting, position shift, orientation in-position, position pulse monitor, etc.
Holding force after positioning	Under V/F control, advanced magnetic flux vector control...without servo lock function Under vector control...with servo lock function
Input signal (contact input)	Orientation command, forward and reverse rotation commands, stop position command (open collector signal input (complementary) is enabled) Binary signal of maximum 16 bit (when used with the FR-A7AX)
Output signal (open collector output)	Orientation complete signal, orientation fault signal

4 ENCODER FEEDBACK CONTROL

When the FR-A7AL is mounted in the FR-A700 series, encoder feedback control is enabled during V/F control and advanced magnetic flux vector control.

This function controls the inverter output frequency so that the motor speed is constant to the load variation by detecting the motor speed with the speed detector (encoder) to feed it back to the inverter.

4.1 Wiring Example

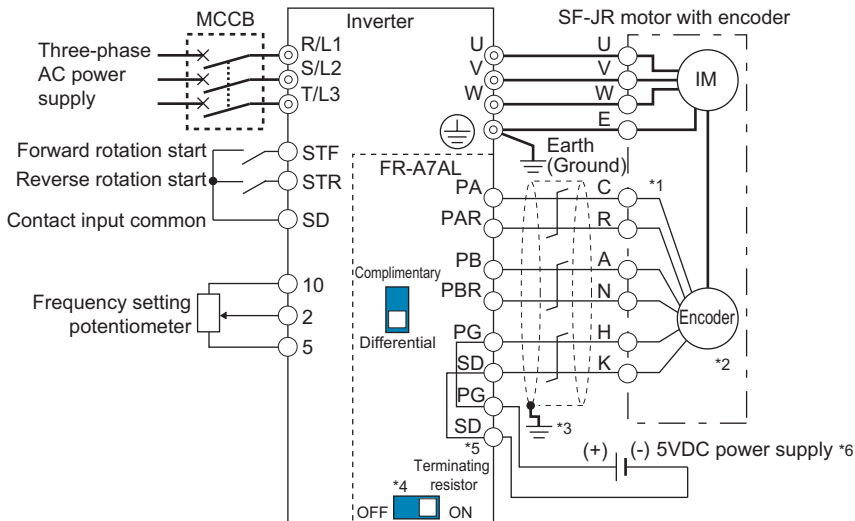

- *1 The pin number differs according to the encoder used.
- *2 The encoder should be coupled on the same axis with the motor shaft without any mechanical looseness. Speed ratio should be 1:1.
- *3 Earth (Ground) the shielded cable of the encoder cable to the enclosure with a P clip, etc. *(Refer to page 13)*
- *4 For the differential line driver, set the terminating resistor selection switch to on position. *(Refer to page 11)*
Note that the terminating resistor switch should be set to off position (initial status) when sharing the same encoder with other unit (CNC, etc) and a terminating resistor is connected to other unit.
For the complementary, set the terminating resistor selection switch to off position (initial status).
Refer to *page 19* for terminal compatibility of the FR-JCBL, FR-V7CBL and FR-A7AL.
- *6 A separate power supply of 5V/12V/15V/24V is necessary according to the encoder power specification.
When performing orientation control together, an encoder and power supply can be shared.



4.2 Terminals

Terminal Symbol	Terminal Name	Description
PA	Encoder A-phase signal input	A-, B-phase signals are input from the encoder. (For details of pulse signal, <i>refer to page 20.</i>)
PAR	Encoder A-phase inverse signal input	
PB	Encoder B-phase signal input	
PBR	Encoder B-phase inverse signal input	
PG	Power supply (positive side) input	Input power for the encoder power supply. Connect the external power supply (5V, 12V, 15V, 24V) and the power cable from encoder.
SD	Power ground	

4.3 Encoder Feedback Control Parameter List

Fitting the FR-A7AL adds the following parameters for encoder control.

Refer to *the inverter manual for details of parameter*.

Parameter Number	Name	Setting Range	Increments	Initial Value
359	Encoder rotation direction	0, 1	1	1
367	Speed feedback range	0 to 400Hz, 9999	0.01Hz	9999
368	Feedback gain	0 to 100	0.1	1
369	Number of encoder pulses	0 to 4096	1	1024
374	Overspeed detection level	0 to 400Hz	0.01Hz	140Hz
376	Encoder signal loss detection enable/disable selection	0, 1	1	0

5 VECTOR CONTROL

When the FR-A7AL is mounted on the FR-A700 series, full-scale vector control operation can be performed using a motor with encoder.

Speed control, torque control, position control (conditional position control with the inverter and FR-A7AL, FR-A7AL and positioning unit of the programmable controller (MELSEC-QD75D, etc.)) by vector control can be performed. (Refer to *the inverter manual for details.*)

Refer to the *section 6* when performing position control using positioning unit of the programmable controller.

5.1 Wiring Example

(1) Standard motor with encoder, 5V differential line driver (speed control)

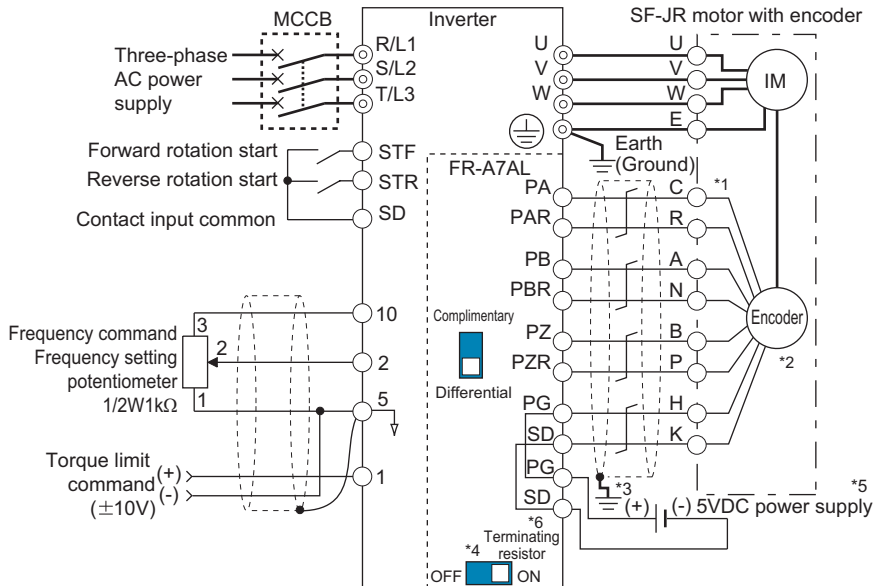



- *1 The pin number differs according to the encoder used.
Speed control and torque control are properly performed even without connecting Z-phase.
- *2 The encoder should be coupled on the same axis with the motor shaft without any mechanical looseness.
Speed ratio should be 1:1.
- *3 Earth (Ground) the shielded cable of the encoder cable to the enclosure with a P clip, etc. *(Refer to page 13)*
- *4 For the differential line driver, set the terminating resistor selection switch to on position. *(Refer to page 11)*
Note that the terminating resistor switch should be set to off position (initial status) when sharing the same encoder with other unit (CNC, etc) and a terminating resistor is connected to other unit.
- *5 A separate power supply of 5V/12V/15V/24V is necessary according to the encoder power specification.
When performing orientation control together, an encoder and power supply can be shared.
- *6 Refer to *page 19* for terminal compatibility of the FR-JCBL, FR-V7CBL and FR-A7AL.

VECTOR CONTROL

(2) Vector control dedicated motor (SF-V5RU), 12V complimentary (torque control)

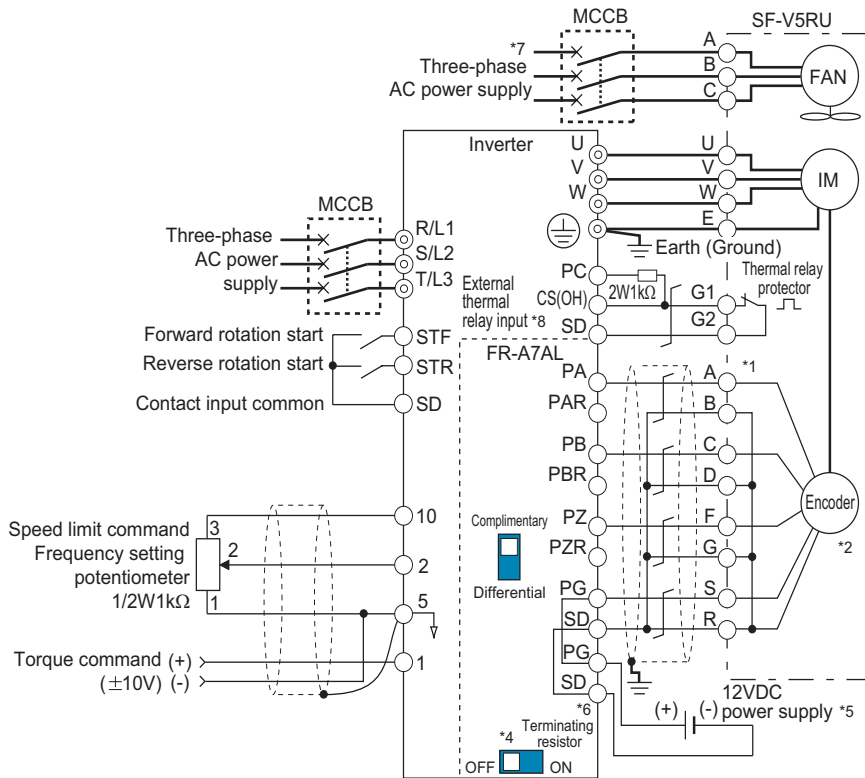

- *1 The pin number differs according to the encoder used.
Speed control and torque control are properly performed even without connecting Z-phase.
- *2 The encoder should be coupled on the same axis with the motor shaft without any mechanical looseness.
Speed ratio should be 1:1.
- *3 Earth (Ground) the shielded cable of the encoder cable to the enclosure with a P clip, etc. *(Refer to page 13)*
- *4 For the complimentary, set the terminating resistor selection switch to off position (initial status) to use. *(Refer to page 11)*
- *5 A separate power supply of 5V/12V/15V/24V is necessary according to the encoder power specification.
When performing orientation control together, an encoder and power supply can be shared.
Refer to *page 19* for terminal compatibility of the FR-JCBL, FR-V7CBL and FR-A7AL.
- *6 For the fan of the 7.5kW or less dedicated motor, the power supply is single phase (200V/50Hz, 200 to 230V/60Hz).
- *7 Assign OH (external thermal input) signal to the terminal CS. (Set "7" in *Pr. 186*.)
Connect a 2W1kΩ resistor between the terminal PC and CS (CH).
Install the resistor pushing it against the bottom part of the terminal block so as to avoid a contact with other cables.
Refer to *the inverter manual for details of Pr. 186 CS terminal function selection*.

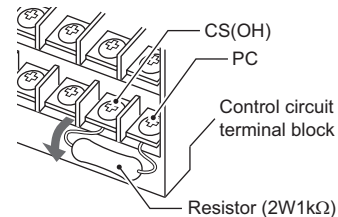

5.2 Terminals

Terminal Symbol	Terminal Name	Description
PA	Encoder A-phase signal input	A-, B- and Z-phase signals are input from the encoder. (For details of pulse signal, <i>refer to page 20.</i>)
PAR	Encoder A-phase inverse signal input	
PB	Encoder B-phase signal input	
PBR	Encoder B-phase inverse signal input	
PZ	Encoder Z-phase signal input	
PZR	Encoder Z-phase inverse signal input	
PG	Power supply (positive side) input	Input power for the encoder power supply. Connect the external power supply (5V, 12V, 15V, 24V) and the power cable from encoder.
SD	Power ground	



5.3 Vector Control Extended Parameter List

The following parameters for orientation control are available when used with the FR-A7AL.

Refer to *the inverter manual for details of parameter.*

Parameter Number	Name	Setting Range	Increments	Initial Value
359	Encoder rotation direction	0, 1	1	1
369	Number of encoder pulses	0 to 4096	1	1024
374	Overspeed detection level	0 to 400Hz	0.01Hz	140Hz
376	Encoder signal loss detection enable/ disable selection	0, 1	1	0
419	Position command source selection	0, 1, 2 *1	1	0
420	Command pulse scaling factor numerator	0 to 32767 *2	1	1
421	Command pulse scaling factor denominator	0 to 32767 *2	1	1
422	Position loop gain	0 to 150sec ⁻¹	1sec ⁻¹	25sec ⁻¹
423	Position feed forward gain	0 to 100%	1%	0
424	Position command acceleration/ deceleration time constant	0 to 50s	0.001s	0s
425	Position feed forward command filter	0 to 5s	0.001s	0s
426	In-position width	0 to 32767 pulses *2	1	100

*1 When the FR-A7AL is fitted, Pr. 419 = "1" (pulse position command by the FR-A7AL) is valid. When the FR-A7AL is not mounted, E.OPT is displayed.

*2 When the operation panel (FR-DU07) is used, the maximum setting is 9999. When a parameter unit is used, up to the maximum value within the setting range can be set.

Parameter Number	Name	Setting Range	Increments	Initial Value
427	Excessive level error	0 to 400K, 9999	1K	40K
428	Command pulse selection	0 to 5	1	0
429	Clear signal selection	0, 1	1	1
430	Pulse monitor selection	0 to 5, 9999	1	9999
432	Pulse train torque command bias	0 to 400%	1%	0
433	Pulse train torque command gain	0 to 400%	1%	150%
464	Digital position control sudden stop deceleration time	0 to 360.0s	0.1s	0
465	First position feed amount lower 4 digits	0 to 9999	1	0
466	First position feed amount upper 4 digits	0 to 9999	1	0
467	Second position feed amount lower 4 digits	0 to 9999	1	0
468	Second position feed amount upper 4 digits	0 to 9999	1	0
469	Third position feed amount lower 4 digits	0 to 9999	1	0
470	Third position feed amount upper 4 digits	0 to 9999	1	0
471	Fourth position feed amount lower 4 digits	0 to 9999	1	0
472	Fourth position feed amount upper 4 digits	0 to 9999	1	0
473	Fifth position feed amount lower 4 digits	0 to 9999	1	0
474	Fifth position feed amount upper 4 digits	0 to 9999	1	0
475	Sixth position feed amount lower 4 digits	0 to 9999	1	0
476	Sixth position feed amount upper 4 digits	0 to 9999	1	0



Parameter Number	Name	Setting Range	Increments	Initial Value
477	Seventh position feed amount lower 4 digits	0 to 9999	1	0
478	Seventh position feed amount upper 4 digits	0 to 9999	1	0
479	Eighth position feed amount lower 4 digits	0 to 9999	1	0
480	Eighth position feed amount upper 4 digits	0 to 9999	1	0
481	Ninth position feed amount lower 4 digits	0 to 9999	1	0
482	Ninth position feed amount upper 4 digits	0 to 9999	1	0
483	Tenth position feed amount lower 4 digits	0 to 9999	1	0
484	Tenth position feed amount upper 4 digits	0 to 9999	1	0
485	Eleventh position feed amount lower 4 digits	0 to 9999	1	0
486	Eleventh position feed amount upper 4 digits	0 to 9999	1	0
487	Twelfth position feed amount lower 4 digits	0 to 9999	1	0
488	Twelfth position feed amount upper 4 digits	0 to 9999	1	0
489	Thirteenth position feed amount lower 4 digits	0 to 9999	1	0
490	Thirteenth position feed amount upper 4 digits	0 to 9999	1	0
491	Fourteenth position feed amount lower 4 digits	0 to 9999	1	0

Parameter Number	Name	Setting Range	Increments	Initial Value
492	Fourteenth position feed amount upper 4 digits	0 to 9999	1	0
493	Fifteenth position feed amount lower 4 digits	0 to 9999	1	0
494	Fifteenth position feed amount upper 4 digits	0 to 9999	1	0
802	Pre-excitation selection	0, 1	1	0
823	Speed detection filter 1	0 to 0.1s	0.001s	0.001s
833	Speed detection filter 2	0 to 0.1s, 9999	0.001s	9999
840	Torque bias selection	0 to 3, 9999	1	9999
841	Torque bias 1	600 to 1400%, 9999	1%	9999
842	Torque bias 2	600 to 1400%, 9999	1%	9999
843	Torque bias 3	600 to 1400%, 9999	1%	9999
844	Torque bias filter	0 to 5s, 9999	0.001s	9999
845	Torque bias operation time	0 to 5s, 9999	0.01s	9999
846	Torque bias balance compensation	0 to 10V, 9999	0.1V	9999
847	Fall-time torque bias terminal 1 bias	0 to 400%, 9999	1%	9999
848	Fall-time torque bias terminal 1 gain	0 to 400%, 9999	1%	9999
853	Speed deviation time	0 to 100s	0.1s	1s
873	Speed limit	0 to 120Hz	0.01Hz	20Hz

5.4 Pulse Train Torque Command

5.4.1 Parameter list

Set the following parameters to give torque command by pulse train.

Parameter Number	Name	Setting Range	Initial Value
432	Pulse train torque command bias	0 to 400%	0%
433	Pulse train torque command gain	0 to 400%	150%
800	Control method selection	0 to 5, 9 to 12, 20	20
804	Torque command source selection	0 to 6	0

5.4.2 Pulse train torque command

When torque control is selected, setting "2" in *Pr. 804 Torque command source selection* enables torque command by pulse train input. Set the *Pr. 800* setting to "1, 2, 5" to perform torque control. (When setting "2" or "5", torque control need to be selected by MC terminal switchover.)

The inverter and torque command pulse train interface should be matched. (Refer to page 36 for wiring.)

Set bias (*Pr. 432*) and gain (*Pr. 433*) to the torque command. The relationship between input pulse and torque command value is as follows.

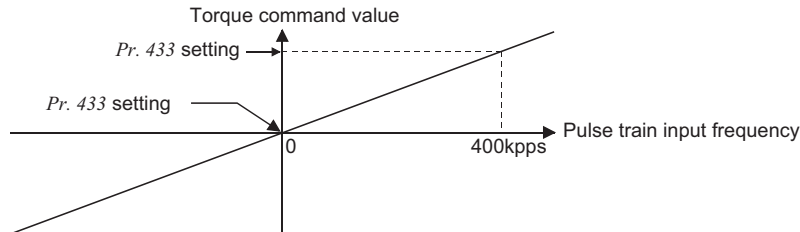

5.5 Specifications

Speed control	Speed control range	1 : 1500 (both driving/regeneration *1)
	Speed variation ratio	$\pm 0.01\%$ (100% means 3000r/min)
	Speed response	300rad/s Note that the internal response is 600rad/s (with model adaptive speed control)
	Maximum speed	120Hz
Torque control	Torque control range	1: 50
	Absolute torque accuracy	$\pm 10\%$ *2
	Repeated torque accuracy	$\pm 5\%$ *2
Function		<ul style="list-style-type: none"> • Setting of speed feedback range • Setting of feedback gain • Setting of encoder rotation direction

*1 Regeneration unit (option) is necessary for regeneration

*2 With online auto tuning (adaptive magnetic flux observer), dedicated motor, rated load

6 POSITION CONTROL FUNCTION

6.1 Position Control by Vector Control

Purpose	Parameter that should be Set		Refer to Page
Position control by the programmable controller positioning unit	Pulse train position command	Pr. 419, Pr. 428 to Pr. 430	69
Adjust the gear ratio of motor and machine	Setting the electronic gear	Pr. 420, Pr. 421, Pr. 424	56
Setting of positioning adjustment parameter	In-position width excessive level error	Pr. 426, Pr. 427	69
Improve position control accuracy	Gain adjustment of position control	Pr. 422, Pr. 423, Pr. 425	71

6.1.1 Position control

- In the position control, the speed command given to rotate the motor is calculated to zero the difference between command pulse (or parameter setting) and the number of feedback pulses from the encoder.
- This option enables position control by the programmable controller positioning unit.

Setting procedure

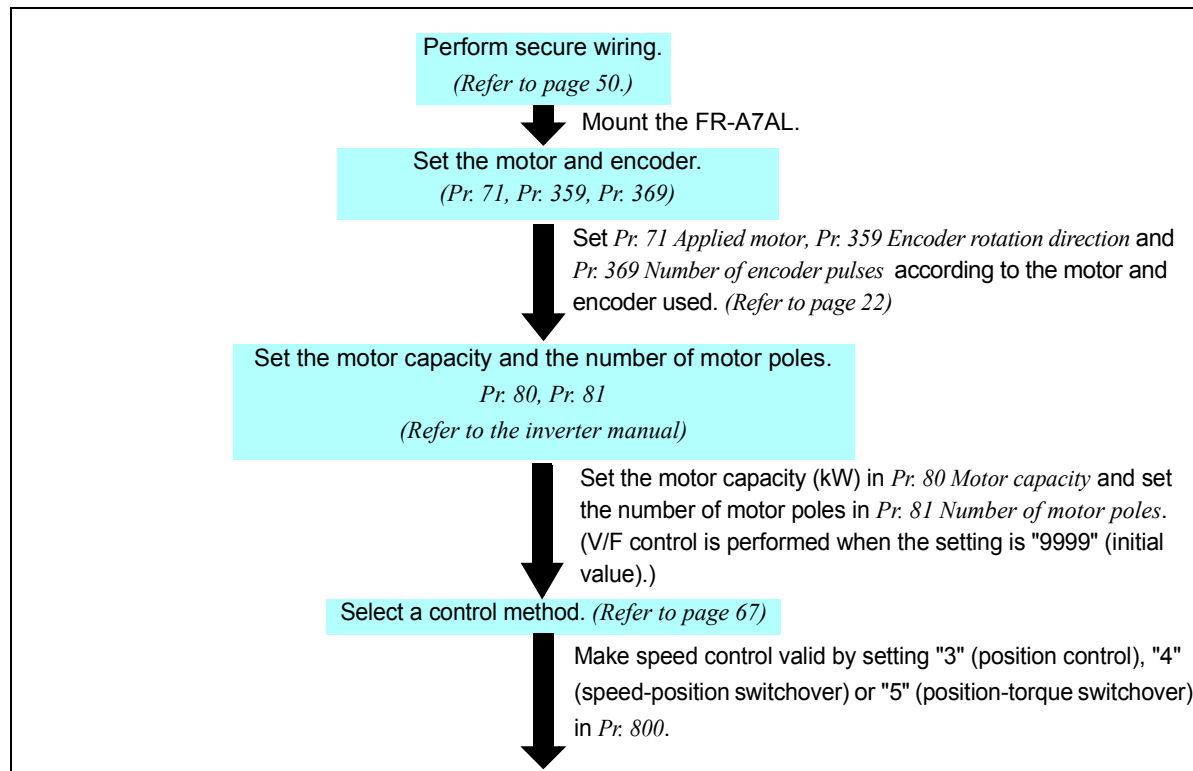

Selection of position command source (Pr. 419.)

Set "1" in Pr.419 for position control by the programmable controller positioning unit.

Setting of parameter for position feed (Pr. 465 to Pr. 494)
(Refer to page 41.)

Test run

As required

- Setting of the electronic gear (refer to page 56)
- Setting of positioning adjustment parameter (refer to page 69)
- Gain adjustment of position control (refer to page 71)

CAUTION

- The carrier frequencies are selectable from among 2k, 6k, 10k, 14kHz for vector control. (2k and 6kHz for the 75K* or more)
- When performing conditional position feed by contact input and position control by the inverter conditional pulse train input, refer to *the inverter manual*.

* 75K ... FR-A720-75K (FR-A720-02880-NA), FR-A740-75K (FR-A740-01440-NA, FR-A740-02160-EC), FR-A760-01040-NA

6.2 Wiring Example

Connection with the MELSEC-Q series QD75D positioning unit

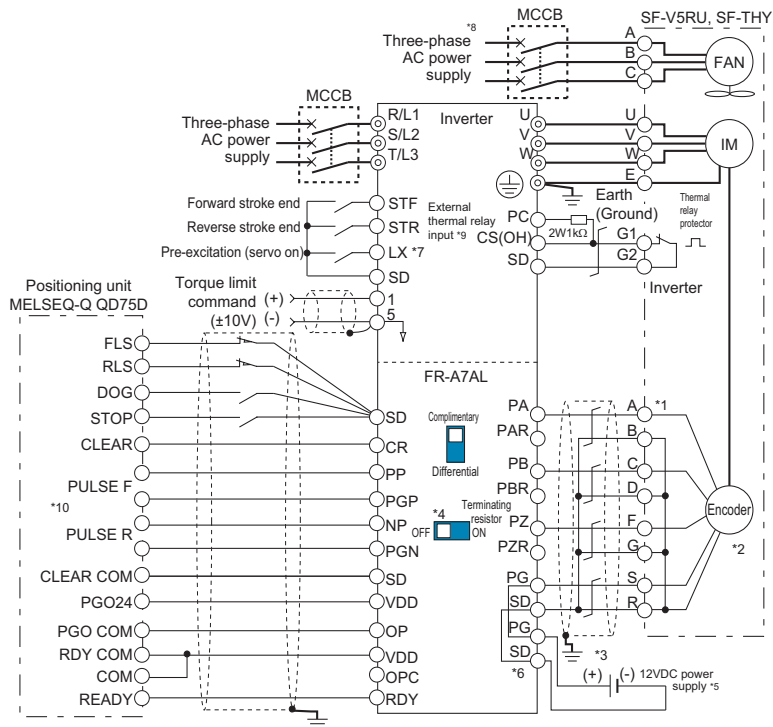

- *1 The pin number differs according to the encoder used.
Position control by pulse train input is properly performed even without connecting Z phase.
- *2 The encoder should be coupled on the same axis with the motor shaft without any mechanical looseness.
Speed ratio should be 1:1.
- *3 Earth (Ground) the shielded cable of the encoder cable to the enclosure with a P clip, etc. (Refer to page 13)
- *4 For the complementary, set the terminating resistor selection switch to off position (initial status) to use. (Refer to page 11)
- *5 A separate power supply of 5V/12V/15V/24V is necessary according to the encoder power specification.
- *6 Refer to page 19 for terminal compatibility of the FR-JCBL, FR-V7CBL and FR-A7AP.
- *7 Assign the function using Pr. 178 to Pr. 184, Pr. 187 to Pr. 189 (input terminal function selection).
- *8 For the fan of the 7.5kW or less dedicated motor, the power supply is single phase (200V/50Hz, 200 to 230V/60Hz).
- *9 Assign OH (external thermal input) signal to the terminal CS. (Pr. 186 = "7")
Connect a 2W1kΩ resistor between the terminal PC and CS (OH).
Install the resistor pushing it against the bottom part of the terminal block so as to avoid a contact with other cables.
Refer to the inverter manual for details of Pr. 186 CS terminal function selection.
- *10 Pulse signal from the positioning unit can be output by either open collector or differential line driver. Note that connection is not the same. (The figure shows the connection in case of differential line driver. Refer to terminal description on page 52 for connection).

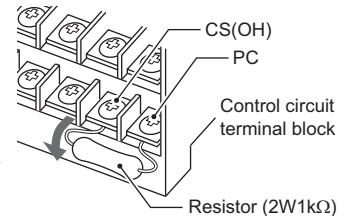

6.3 Terminals

Terminal Symbol	Terminal Name	Specification	Description	
PGP PP	Forward rotation pulse train	Open collector /differential line driver	Forward rotation pulse train input terminal Input pulse train from the pulse generating unit.	For open collector, connect terminal VDD and OPC, then input pulses across terminal PP-SD and NP-SD. For differential line driver, open terminal OPC, then input pulse across terminal PP-PGP and NP-PGN.
PGN NP	Reverse rotation pulse train		Reverse rotation pulse train input terminal Input pulse train from the pulse generating unit.	
CR	Clear	—	Shortning terminal CR-SD clears counter at the rising edge.	
OPC	Open collector power input	24VDC	When inputting pulse by open collector method, connect this terminal to terminal VDD (24V power supply).	
SD	Contact input common	—	Contact input common terminal. Do not earth (ground).	
VDD	Driver power supply	24VDC	Driver power supply terminal for interface.	
RDY	Preparation ready signal	—	When servo ON and ready to drive, the signal is output.	
OP	Encoder Z-phase output	Open collector output permissible load 24VDC, max. 50mA	Outputs one pulse per motor revolution.	

6.4 Operation

The speed command given to rotate the motor is calculated to zero the difference between the number of pulse train pulses and the number of pulses feed back from the motor end encoder.

- 1) When a pulse train (MELSEC-Q series positioning unit QD75D, etc.) is input, pulses are accumulated in the deviation counter and these droop pulses act as position control pulses to give the speed command.
- 2) As soon as the motor starts running under the speed command of the inverter, the encoder generates feed back pulses and the droop of the deviation counter is counted down. The deviation counter maintains a given droop pulse value to keep the motor running.
- 3) When the command pulse input stops, the droop pulses of the deviation counter decreases, reducing the speed. The motor stops when there are no droop pulses.
- 4) When the number of droop pulses has fallen below the value set in *Pr. 426 In-position width*, it is regarded as completion of positioning and the in-position signal (Y36) turns on.

POSITION CONTROL FUNCTION

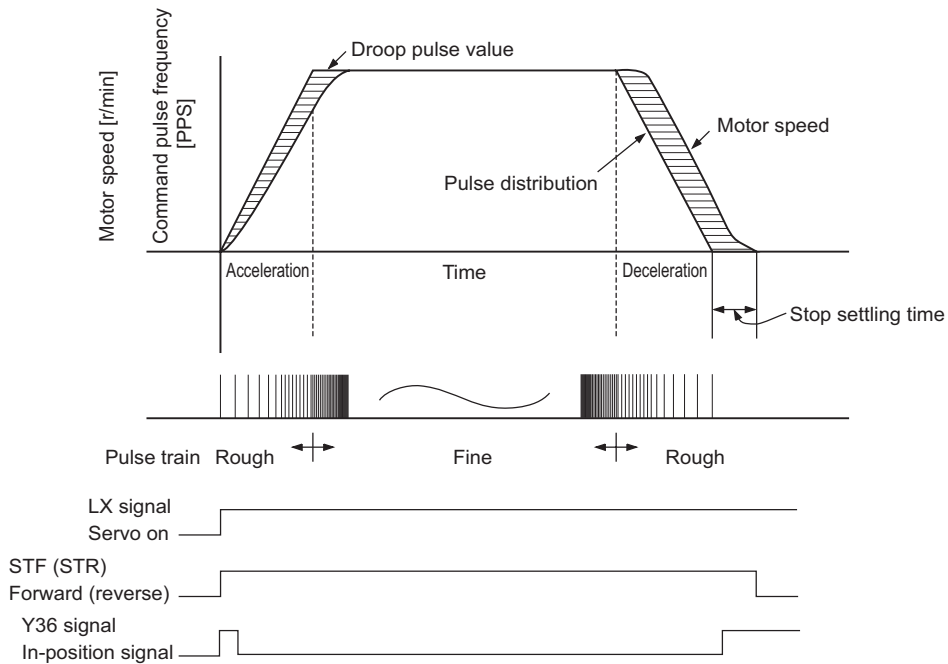

- The pulse train is rough during acceleration and coarse at the maximum speed. During deceleration the pulse train is rough and at last there are no pulses. The motor stops shortly after the command pulses stop. This time lag is necessary for maintaining the stop accuracy and called stop settling time.

REMARKS

- For the servo on signal (LX), set "23" in Pr. 178 to Pr. 189 (input terminal function selection) to assign the function.
- For the in-position signal (Y36), set "36" in Pr. 190 to Pr. 196 (output terminal function selection) to assign the function.

6.4.1 Operation by position command using pulse train

Turning on (short the terminal LX-SD) the servo on signal cancels the base circuit shut-off and operation ready signal is output after 0.1s has passed. (Assign the servo on (LX) signal using input function selection (Pr. 178 to Pr. 189).) When the terminal STF (forward stroke end signal) or terminal STR (reverse stroke end signal) and terminal SD are shorted, the motor runs in accordance with the command pulse. When the forward (reverse) stroke end signal opens, the motor does not run in that direction.

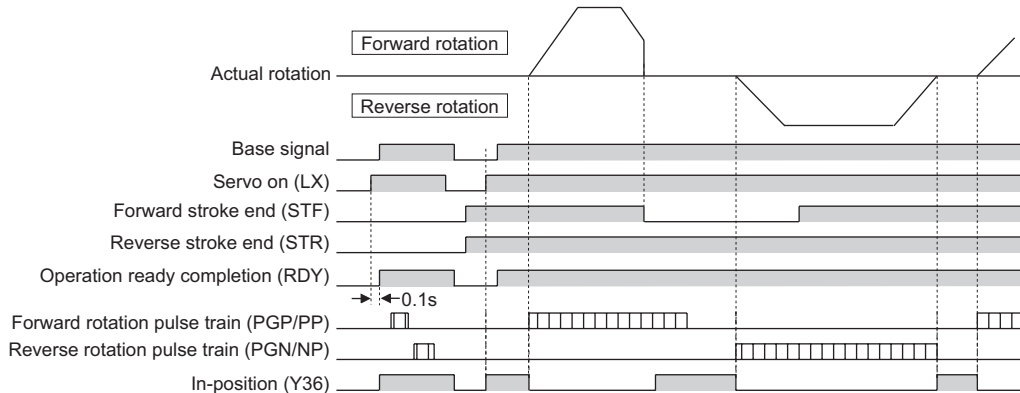

6.4.2 Initial setting

- (1) Shortening the terminal LX-SD (servo on) switches the servo on and cancels the base circuit shut-off, resulting in a servo lock status.
- (2) Opening terminal LX-SD shutting the base circuit.
- (3) Short the terminal STF (forward rotation stroke end) or terminal STR (reverse rotation stroke end) and the SD terminal.
- (4) When command pulse is input, the motor rotates in response to the pulse command.

6.4.3 Setting the electronic gear (Pr. 420, Pr. 421, Pr. 424)

Set the ratio of the machine side gear and the motor side gear.

Parameter Number	Name	Initial Value	Setting Range	Description
420	Command pulse scaling factor numerator	1	0 to 32767 *	Set the electronic gear. <i>Pr. 420</i> is a numerator and <i>Pr. 421</i> is a denominator.
421	Command pulse scaling factor denominator	1	0 to 32767 *	
424	Position command acceleration/ deceleration time constant	0s	0 to 50s	Used when rotation has become unsmooth at a large electronic gear ratio (about 10 times or more) and low speed.

The above parameters can be set when the FR-A7AL (option) is mounted.

* When the operation panel (FR-DU07) is used, the maximum setting is 9999. When a parameter unit is used, up to the maximum value within the setting range can be set.

(1) Calculation of the gear ratio (*Pr. 420, Pr. 421*)

- The position resolution (travel per pulse $\Delta \ell$ [mm]) is determined by the travel per motor revolution Δs [mm] and the feedback pulses Pf [pulse/rev] of the detector, and is represented by the following expression.

$$\Delta \ell \times \frac{\Delta s}{\text{Pf}}$$

$\Delta \ell$: travel per pulse [mm]
 Δs : travel per motor rotation [mm]
 Pf : number of feedback pulses [pulse/rev]
 (number of pulses after multiplying the number of encoder pulses by four)

Using the parameters, the travel per command pulse can be set separately to set the travel per command pulse without a fraction.

$$\Delta \ell = \frac{\Delta s}{\text{Pf}} \times \frac{\text{Pr. 420}}{\text{Pr. 421}}$$

In addition, the relationship between the motor speed and internal command pulse frequency is as follows:

$$f_o \times \frac{\text{Pr. 420}}{\text{Pr. 421}} = \text{Pf} \times \frac{\text{No}}{60}$$

f_o : internal command pulse frequency [pps]
 No: motor speed [r/min]

CAUTION

Set the electronic gear in the range of 1/50 to 20.

Note that too small a value will decrease the speed command and too large a value will increase the speed ripples.

"Setting example 1"

Example of setting the command pulse scale factor (*Pr. 420, Pr. 421*) when the QD75D is used

Find the command pulse scale factor for running the motor at 1500 (r/min) at the input pulse train frequency of 100 (kpps).

- When the SF-V5RU motor is used

Number of feed back pulses is $P_f = 8192$ (pulse/rev)

$$\begin{aligned}\frac{Pr. 420}{Pr. 421} &= 8192 \times \frac{No}{60} \times \frac{1}{fo} \\ &= 8192 \times \frac{1500}{60} \times \frac{1}{100 \times 10^3} = \frac{2048}{1000}\end{aligned}$$

Therefore, set "2048" in *Pr. 420* and "1000" in *Pr. 421*.

"Setting example 2"

Find the command pulse frequency which sets the motor speed $N_o = 3000$ (r/min).

Note that the command pulse scaling factor $Pr. 420/Pr. 421 = "1"$.

- When the SF-V5RU motor is used

Number of feed back pulses is $P_f = 8192$ (pulse/rev)

$$\begin{aligned} f_o &= 8192 \times \frac{N_o}{60} \times \frac{Pr. 421}{Pr. 420} \\ &= 8192 \times \frac{3000}{60} \times \frac{1}{1} = 409.6 \times 10^3 \end{aligned}$$

Therefore the command pulse is 409.6 (kpps).

CAUTION

If the pulse train input is open collector, command pulse frequency is max. 200kpps.

Therefore, the command pulse frequency should be set to 200kpps using command pulse scaling factor of $Pr. 420/Pr. 421$.

(2) Relationship between position resolution $\Delta \ell$ and overall accuracy

Since overall accuracy (positioning accuracy of machine) is the sum of electrical error and mechanical error, normally take measures to prevent the electrical system error from affecting the overall error. As a guideline, refer to the following relationship.

$$\Delta \ell < \left(\frac{1}{5} \text{ to } \frac{1}{10} \right) \times \Delta \varepsilon \quad \Delta \varepsilon: \text{positioning accuracy}$$

< Stopping characteristic of motor >

When parameters are used to run the motor, the internal command pulse frequency and motor speed have the relationship as shown in the chart on *page 54*, and as the motor speed decreases, pulses are accumulated in the deviation counter of the inverter. These pulses are called droop pulses (ε) and the relationship between command frequency (f_0) and position loop gain (K_p : *Pr. 422*) is as represented by the following formula.

$$\varepsilon = \frac{f_0}{K_p} \quad [\text{pulse}] \quad \varepsilon = \frac{204800}{25} \quad [\text{pulse}] \quad (\text{rated motor speed})$$

When the initial value of K_p is 25s^{-1} , the droop pulses (ε) are 8192 pulses.

Since the inverter has droop pulses during running, a stop settling time (t_s) is needed from when the command has zeroed until the motor stops. Set the operation pattern in consideration of the stop settling time.

$$t_s = 3 \times \frac{1}{K_p} \quad [\text{s}]$$

When the initial value of K_p is 25s^{-1} , the stop settling time (t_s) is 0.12s.
The positioning accuracy $\Delta \varepsilon$ is $(5 \text{ to } 10) \times \Delta \ell = \Delta \varepsilon$ [mm]

CAUTION

The stop settling time (t_s) indicates the time until the pulse of the motor encoder enters the positioning accuracy range. It does not indicate the time required for the motor to stop completely. When high positioning accuracy is required for the travel per pulse ($\Delta \ell$) in high duty applications, for example, a longer setting time than the value derived from the above formula must be considered. Note that t_s also differs with the conditions of the moving sections. Particularly at a large load friction torque, the motor may run unstably when it is coming to a stop.



(3) Position command acceleration/deceleration time constant (*Pr. 424*)

- When the electronic gear ratio is large (about 10 or more times) and the speed is low, rotation will not be smooth, resulting in pulse-wise rotation. At such a time, set this parameter to smooth the rotation.
- When acceleration/deceleration time cannot be provided for the command pulses, a sudden change in command pulse frequency may cause an overshoot or error excess alarm. At such a time, set this parameter to provide acceleration/deceleration time.
Normally set 0.

6.5 Pulse Input Type

Command pulse can be changed according to the positioning unit as in the table below.

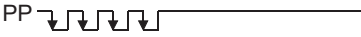
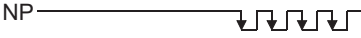
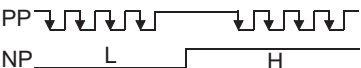
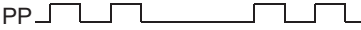
(1) Pulse train form (Pr. 428)

Command Pulse Train Form		At Forward Rotation	At Reverse Rotation	Setting Pr. 428	Remarks
Negative logic	Forward rotation pulse train Reverse rotation pulse train	 		0 (factory setting)	QD75D(CW/CWW mode) (Note) If (CW/CWW mode) and (PLS/SIGN mode) are misselected, the motor runs only in one direction.
	Pulse train + sign			1	QD75D (PLS/SIGN mode)
	A phase pulse train B phase pulse train	 		2	Counted after multiplying by four. Set the pulse train frequency multiplied by four to 500kpps or less with the differential driver type and to 200kpps or less with the open collector type.

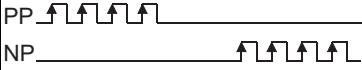
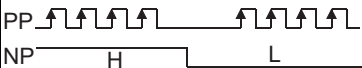
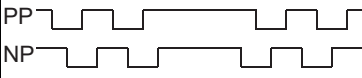
Command Pulse Train Form		At Forward Rotation	At Reverse Rotation	Setting <i>Pr. 428</i>	Remarks
Positive logic	Forward rotation pulse train Reverse rotation pulse train			3	
	Pulse train + sign			4	
	A phase pulse train B phase pulse train			5	Counted after being multiplied by four. Set the pulse train frequency multiplied by four to 500kpps or less with the differential driver type and to 200kpps or less with the open collector type.

6.6 Interface of the Positioning Unit and Inverter

When running the inverter by each positioning unit, interface of the positioning command pulse train need to be matched.

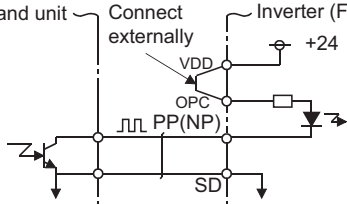
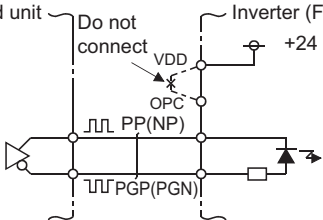
Output Type	Hardware Configuration	Input Pulse Frequency
<p>Open collector</p>	<p>Command unit</p> <p>Connect externally</p> <p>Inverter (FR-A7AL)</p> <p>VDD</p> <p>+24</p> <p>OPC</p> <p>PP(NP)</p> <p>SD</p>  <p>*: Wiring length : max. 2m</p>	<p>Max. 200kpps</p>
<p>Differential line driver</p>	<p>Command unit</p> <p>Do not connect</p> <p>Inverter (FR-A7AL)</p> <p>VDD</p> <p>+24</p> <p>OPC</p> <p>PP(NP)</p> <p>PGP(PGN)</p>  <p>*: Wiring length : max. 10m</p>	<p>Max. 500kpps</p>

6.7 Extended Function Parameter List

The following parameters for position control are available when used with the FR-A7AL. (except for *Pr. 800*)

Parameter Number	Name	Setting Range	Unit	Initial Value	Refer to Page
419	Position command source selection	0, 1, 2 *	1	0	69
420	Command pulse scaling factor numerator	0 to 32767	1	1	56
421	Command pulse scaling factor denominator	0 to 32767	1	1	56
422	Position loop gain	0 to 150s ⁻¹	1s ⁻¹	25s ⁻¹	71
423	Position feed forward gain	0 to 100%	1%	0%	71
424	Position command acceleration/ deceleration time constant	0 to 50s	0.001s	0s	56
425	Position feed forward command filter	0 to 5s	0.001s	0s	71
426	In-position width	0 to 32767 pulses	1 pulses	100 pulses	69
427	Excessive level error	0 to 400K pulse, 9999	1K pulses	40K pulses	69
428	Command pulse selection	0 to 5	1	0	62
429	Clear signal selection	0, 1	1	1	73
430	Pulse monitor selection	0 to 5, 9999	1	9999	70
800	Control method selection	0 to 5, 9 to 12, 20	1	20	67

* When the FR-A7AL is fitted, *Pr. 419* = "1" (pulse position command by the FR-A7AL) is valid. When the FR-A7AL is not fitted, E.OPT is displayed.

6.8 Parameter Setting and Details

When performing position control with the FR-A7AL, set the following parameters.

6.8.1 Block diagram

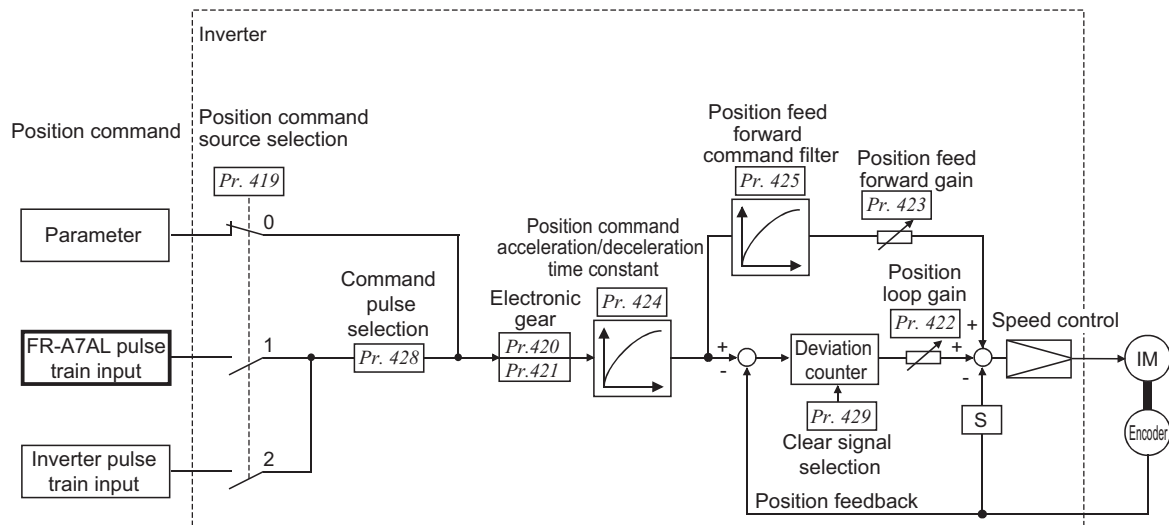

6.8.2 Selection of control method (Pr. 800)

Set the *Pr. 800* setting to "3, 4, 5" to perform position control. Control circuit terminal function changes depending on parameter setting.

(When the setting is "4 or 5", select position control by switching MC signal.)

Refer to *the inverter manual* for details.

<i>Pr. 800</i> Setting	Control Method	Control Mode	Remarks
0	Vector control	Speed control	—
1		Torque control	—
2		Speed control-torque control switchover	MC signal: ON Torque control MC signal: OFF Speed control
3		Position control	—
4		Speed control-position control switchover	MC signal: ON Position control MC signal: OFF Speed control
5		Position control-torque control switchover	MC signal: ON Torque control MC signal: OFF Position control
9		Vector control test operation	
10	Real sensorless vector control	Speed control	—
11		Torque control	—
12		Speed control-torque control switchover	MC signal: ON Torque control MC signal: OFF Speed control
20 (initial value)	V/F control or advanced magnetic flux vector control		

7 POSITION CONTROL FUNCTION

Terminal function changes by control mode switchover as below.

Classification	Terminal Name	Description				
		<i>Pr. 800 = "3"</i>	<i>Pr. 800 = "4"</i>		<i>Pr. 800 = "5"</i>	
		Position control	Speed control MC signal: ON	Position control MC signal: OFF	Position control MC signal: ON	Torque control MC signal: OFF
Contact input signal	STF	Forward stroke end	Forward rotation command	Forward stroke end	Forward stroke end	Forward rotation command
	STR	Reverse stroke end	Reverse rotation command	Reverse stroke end	Reverse stroke end	Reverse rotation command

REMARKS

Assign MC signal to *Pr. 180 to Pr. 188*. Set any of *Pr. 180 to Pr. 188* to "26".

For analog input terminal, function changes according to *Pr. 858 Terminal 4 function assignment, Pr. 868 Terminal 1 function assignment* setting. (Refer to *inverter manual* for details.)

6.8.3 Position control

- (1) Position command source selection (*Pr. 419*)

When using the FR-A7AL, set "1" in *Pr. 419*.

<i>Pr. 419</i> Setting	Description
0 (initial value)	Conditional position feed function by contact input (by parameter).
1	Position command by pulse train input (when the FR-A7AL is fitted).
2	Conditional pulse train position command by inverter pulse train input.

- (2) In-position width (*Pr. 426*)

The Y36 terminal signal acts as an in-position signal.

The in-position signal turns on when the number of droop pulses becomes less than the setting.

- (3) Excessive level error (*Pr. 427*)

An error becomes excessive when the droop pulses exceed the setting.

When you decreased the position loop gain (*Pr. 422*) setting, increase the error excessive level setting.

Also decrease the setting when you want to detect an error slightly earlier under large load.

When "9999" is set in *Pr. 427*, position error large (E.OD) does not occur regardless of droop pulses.

(4) Pulse monitor selection (*Pr. 430*)

The status of various pulses during running are displayed.

Set "6" in *Pr. 52 DU/PU main display data selection* to display output frequency monitor.

<i>Pr. 430</i> Setting	Description	Display Range (FR-DU07)	Display Range (FR-PU04, FR-PU07)
0	The cumulative command pulse value is displayed.	Lower 4 digits	Lower 5 digits
1		Upper 4 digits	Upper 5 digits
2	The cumulative feedback pulse value is displayed.	Lower 4 digits	Lower 5 digits
3		Upper 4 digits	Upper 5 digits
4	The droop pulses are monitored.	Lower 4 digits	Lower 5 digits
5		Upper 4 digits	Upper 5 digits
9999 (initial value)	Frequency monitor is displayed.		

REMARKS

- Count the number of pulses when the servo is on.
- The cumulative pulse value is cleared when the base is shut off or the clear signal (CLR) is turned on.

6.8.4 Gain adjustment of position control (Pr. 422, Pr. 423, Pr. 425)

Easy gain tuning is available as an easy tuning method. Refer to the *inverter manual* for easy gain tuning. If it does not produce any effect, make fine adjustment by using the following parameters. Set "0" in *Pr. 819 Easy gain tuning selection* before setting the parameters below.

Parameter Number	Name	Initial Value	Setting Range	Description
422	Position loop gain	$25s^{-1}$	0 to $150s^{-1}$	Set the gain of the position loop.
423	Position feed forward gain	0%	0 to 100%	Function to cancel a delay caused by the droop pulses of the deviation counter.
425	Position feed forward command filter	0s	0 to 5s	Enters the primary delay filter in response to the feed forward command.

(1) Position loop gain (*Pr. 422*)

Make adjustment when any of such phenomena as unusual vibration, noise and overcurrent of the motor/machine occurs.

Increasing the setting improves trackability for the position command and also improves servo rigidity at a stop, but oppositely makes an overshoot and vibration more liable to occur.

Normally set this parameter within the range about 5 to 50.

Phenomenon/ Condition	Adjustment Method	
Slow response	Increase the <i>Pr. 422</i> value.	
	<i>Pr. 422</i>	Increase the value $3s^{-1}$ by $3s^{-1}$ until just before an overshoot, stop-time vibration or other instable phenomenon occurs, and set about 0.8 to 0.9 of that value.
Overshoot, stop-time vibration or other instable phenomenon occurs.	Decrease the <i>Pr. 422</i> value.	
	<i>Pr. 422</i>	Decrease the value $3s^{-1}$ by $3s^{-1}$ until just before an overshoot, stop-time vibration or other instable phenomenon occurs, and set about 0.8 to 0.9 of that value.

(2) Position feed forward gain (*Pr. 423*)

This function is designed to cancel a delay caused by the droop pulses of the deviation counter.

When a tracking delay for command pulses poses a problem, increase the setting gradually and use this parameter within the range where an overshoot or vibration will not occur.

This function has no effects on servo rigidity at a stop.

Normally set this parameter to "0".

6.8.5 Selection of clear signal (Pr. 429, CR signal)

- Use this function to make a drooping pulse 0 for home position operation, etc.
- When "0" is set in Pr. 429 , the deviation counter is cleared at the edge of turning on of the clear signal (CR). The CR signal turns on in synchronization with the zero pulse signal of encoder for home position operation, etc. and clears the deviation counter.

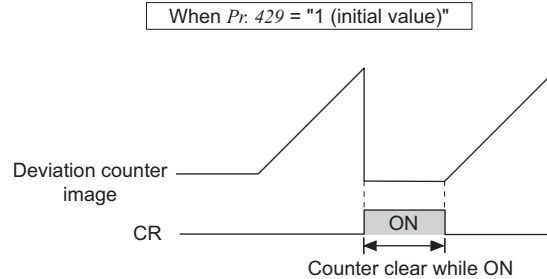
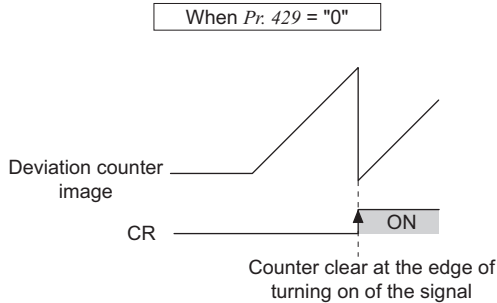

6.8.6 Troubleshooting

	Phenomenon	Cause	Countermeasures
1	Motor does not rotate	(1) The phase sequence of the motor or encoder wiring is wrong. (2) The control mode selection, <i>Pr. 800</i> , setting is improper. (3) The servo on signal or stroke end signal (STF, STR) is not input. (4) Command pulse, position pulse sign (NP) are not correctly input. (5) The <i>Pr. 419 Position command source selection</i> , setting is not correct. (6) When the <i>Pr. 419 Position command source selection</i> setting is 0, the position feed amount, <i>Pr. 465 to Pr. 494</i> , settings are not correct.	(1) Check the wiring (<i>Refer to page 50</i>) (2) Check the <i>Pr. 800</i> setting. (<i>Refer to page 67</i>) (3) Check that the signals are input normally. (4) -1 Check that the command pulses are input normally. (Check the cumulative command pulse value in <i>Pr. 430</i>) (4)-2 Check the command pulse form and command pulse selection, <i>Pr. 428</i> , setting. (5) Check the position command source selection in <i>Pr. 419</i> . (6) Check the position feed amount in <i>Pr. 465 to Pr. 494</i> .

	Phenomenon	Cause	Countermeasures
2	Position shift occurs.	(1) The command pulses are not input correctly. (2) The command is affected by noise. Or the encoder feedback signal is compounded with noise.	(1)-1 Check the command pulse form and command pulse selection, <i>Pr. 428</i> , setting. (1) -2 Check that the command pulses are input normally. (Check the cumulative command pulse value in <i>Pr. 430</i>) (2)-1 Decrease <i>Pr. 72 PWM frequency selection</i> . (2)-2 Change the earthing (grounding) point of shielded wire. Or leave the cable suspended.
3	Motor or machine hunts.	(1) The position loop gain is high. (2) The speed loop gain is high.	(1) Decrease the <i>Pr. 422</i> value. (2)-1 Perform easy gain tuning. (2)-2 Decrease <i>Pr. 820</i> and increase <i>Pr. 821</i> .
4	Machine operation is unstable	(1) The acceleration/deceleration time setting has adverse effect.	(1) Decrease <i>Pr. 7</i> and <i>Pr. 8</i> .

6.9 Specifications

Repeated positioning accuracy	$\pm 1.5^\circ$ (motor shaft end) (changes according to load torque, moment of inertia J or backlash condition of load)
Holding force after positioning	with servo lock
Power supply	24V power supply output for interface driver is provided
Maximum input pulse frequency	Differential line receiver: 500kpps, open collector: 200kpps
Positioning return pulse	Number of encoder pulses per motor rotation \times 4 times
Electronic gear setting	1/50 to 20
In-position width setting	0 to 32767 pulses
Error excess	0 to 400K pulses

7 ENCODER PULSE DIVIDING OUTPUT

Pulse input of encoder connected to the inverter is divided and output from the FR-A7AL terminal.

7.1 Wiring Example

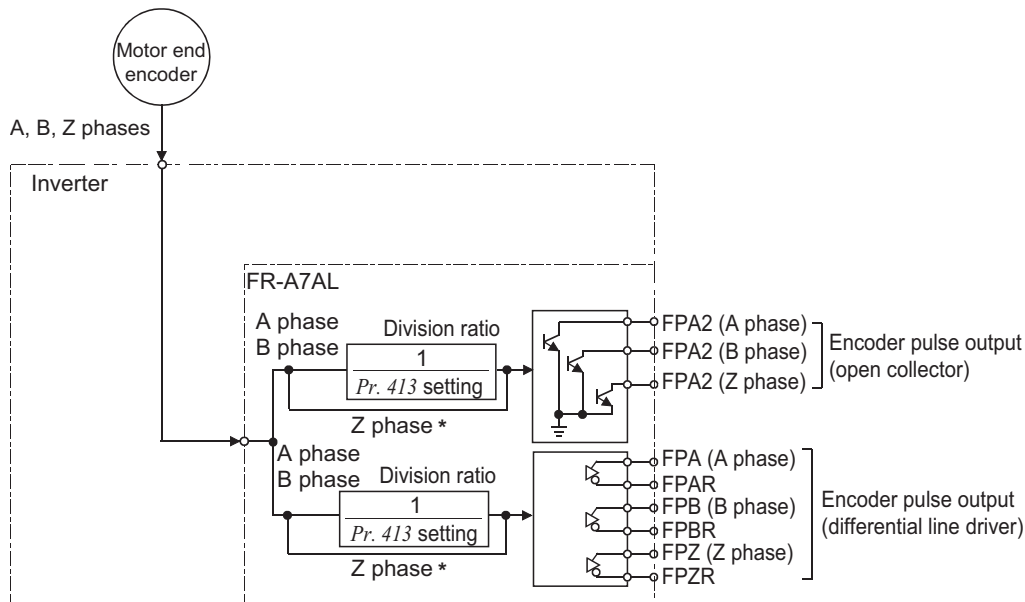

* Z phase can not be divided.

CAUTION

For open collector output, the signal may become unstable if the input resistance of the connected device is large and the device may detect the signal incorrectly. In this case, adding a pull up resistance as shown below will improve the phenomenon.

Select a pull-up resistance in consideration of the input current of the connected device so that the open collector output current will not exceed the output permissible load current.

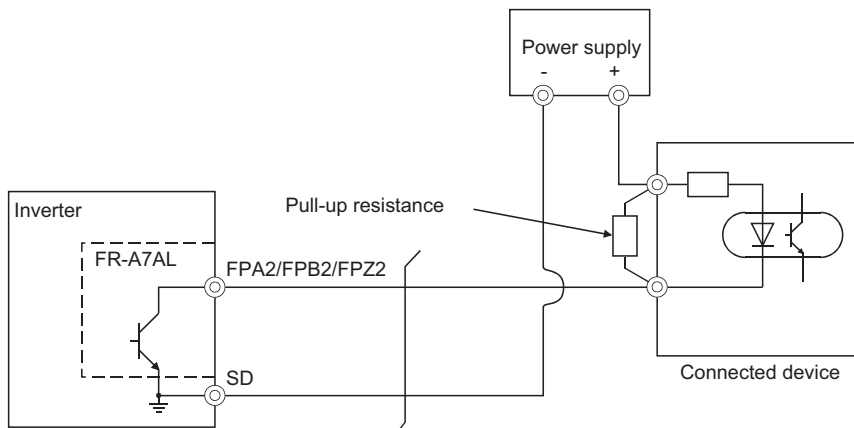



7.2 Terminals

Open collector

Terminal Symbol	Terminal Name	Specification	Description
FPA2	A-phase output	Open collector Output permissible load 24VDC, max. 50mA	A-, B- and Z-phase (origin and mark pulse) signals are output from the encoder. A-phase and B-phase signal is divided and can be output as division ratio (1/n) n = 1 to 32767 (integer number). Set frequency dividing using <i>Pr.413 Encoder pulse division ratio</i> . Common terminal is terminal SD.
FPB2	B-phase output		
FPZ2	Z-phase output		

ENCODER PULSE DIVIDING OUTPUT

Differential line driver

Terminal Symbol	Terminal Name	Specification	Description
FPA	Differential A-phase output	Differential line driver output Permissible load 0.1A	A-, B- and Z-phase (origin and mark pulse) signals are output from the encoder. A-phase and B-phase signal is divided and can be output as division ratio (1/n) n = 1 to 32767 (integer number). Set frequency dividing using <i>Pr.413 Encoder pulse division ratio</i> .
FPAR	Differential A-phase inversion signal output		
FPB	Differential B-phase output		
FPBR	Differential B-phase inversion signal output		
FPZ	Differential Z-phase output		
FPZR	Differential Z-phase inversion signal output		

*1 The division ratio setting is same for open collector output and differential line driver output.



7.3 Encoder

Parameter Number	Name	Initial Value	Setting Range	Description
413	Encoder pulse division ratio	1	1 to 32767	The encoder pulse signal at the motor end can be divided in division ratio set in <i>Pr. 413</i> and output. Use this parameter to make the response of the machine to be input slower, etc.

- Division waveform by division ratio
Both ON-OFF width is division times. (50% duty)
Pulse waveform example at 1000 pulse input when *Pr. 413* = "2"

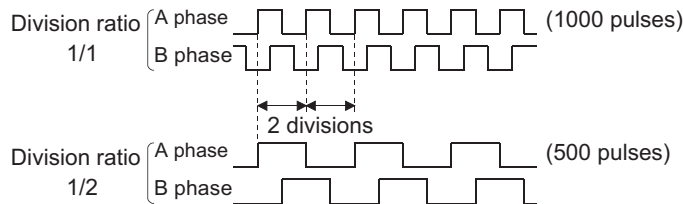

REMARKS

Control of forward rotation/reverse rotation by phase difference between A phase and B phase.

- When A phase is 90° advanced as compared to B phase: forward rotation
- When A phase is 90° behind as compared to B phase: reverse rotation

REVISIONS

*The manual number is given on the bottom left of the back cover.

Print Date	*Manual Number	Revision
Oct., 2007	IB(NA)-0600310ENG-A	First edition